

Gru a bandiera

Jib cranes



Gru a bandiera

Jib cranes

The jib crane is the most practical and economical solution to make independent a workplace otherwise requiring the use of a bridge crane or forklift. In addition, a jib crane solves the issue of load handling in tight spaces where different lifting equipment would not be able to operate.

SPECIFICATION

Column

Manufactured with bent and reinforced steel sheets, column is provided with a drilled plate at one end and with two plates suitable to support the jib at the opposite side.

Bracket

Two plates connected rigidly each other to support the jib, tightened to the pillar with counter supports and tie rods.

Jib

The jib is always mounted on bearings and can be manufactured with T or H beam, with or without support tie rod, or press-formed Ω shaped profile.

Brake system

A clutch system with adjustable screw pressure system to allow adjusting the rotation effort of the jib and ensure its positioning stability.

Hoist

Kito electric chain hoist, safe and reliable, with one or two lifting speeds, with electric or manual trolley.

Power supply

Fire proof festoon cable, sliding in a channel profile or under the jib through small trolleys, and junction box for connection to the power supply.

Anchor and chemical bolts

Depending on the type of floor, capacity and jib length, the column-mounted jib cranes are fastened to the floor through a foundation cage inserted in a plinth and buried in concrete, or with the use of special chemical bolts.

Steel rods and supports

In order to anchor the wall-mounted jib cranes to the pillar, steel rods and supports are sized depending on capacity and jib length.

Painting

For indoor application (standard climate, indoor and dry) the following painting cycle takes place:

Mechanical brushing of the surface, cleaning and degreasing;

Painting with anticorrosive, ecological alkyd enamel, weather and abrasion resistant.

Total dry film thickness: 70-80 μm .

COMPLIANCE WITH DIRECTIVES AND STANDARDS

The design of the crane complies with fem 1001 standard for steel structures and lifting equipment.

Fas jib cranes comply with 2006/42/EC Machine Directive, and they are supplied with CE mark, Certification of Compliance and use and maintenance manual.

La gru a bandiera è la soluzione più pratica ed economica per rendere autonomo un posto di lavoro che, altrimenti, richiederebbe l'impiego del carrozzone o del carrello elevatore.

Inoltre, la gru a bandiera risolve il problema della movimentazione dei carichi negli spazi limitati dove altri mezzi di sollevamento non potrebbero operare.

CARATTERISTICHE

Colonna

Realizzata in lamiera di acciaio rinforzata con, ad una estremità, una piastra di base forata per il fissaggio al basamento mediante tirafondi o tasselli e dall'altra due piastre per sostenere il braccio.

Mensola

Composta da due piastre piegate e nervate collegate rigidamente tra loro. Le piastre sono forate per il fissaggio al pilastro con barre filettate e controstaffe.

Braccio

Il braccio è sempre montato su cuscinetti e può essere realizzato con trave a doppio T, con o senza tirante di sostegno, o in profilo pressopiegato a forma di Ω .

Dispositivo frenante

È costituito da una frizione regolabile a vite che permette la regolazione dello sforzo di rotazione del braccio e ne assicura la stabilità di posizionamento.

Paranco

Paranco elettrico a catena Kito, sicuro e affidabile, a una o due velocità di sollevamento, con carrello manuale o elettrico.

Linea di alimentazione

Con cavo a festone di tipo antifiama, scorrevole in una canalina o sotto il braccio stesso mediante carrellini, e scatola di derivazione per collegamento alla linea.

Tirafondi e tasselli

In funzione del tipo di basamento, della portata e della lunghezza del braccio, le gru a colonna vengono fissate al pavimento mediante una gabbia di fondazione inserita in un plinto e annegata con il calcestruzzo, oppure con l'utilizzo di appositi tasselli chimici.

Barre filettate e controstaffe

Per imbragare al pilastro le gru a mensola, dimensionate in funzione della portata e della lunghezza del braccio.

Verniciatura

Per impianti installati all'interno (clima normale, interno ed asciutto) è previsto un ciclo di verniciatura così composto:

Spazzolatura meccanica della superficie, sgrassaggio e pulizia accurata;

Verniciatura con smalto anticorrosivo alchilico ecologico resistente agli agenti atmosferici ed all'abrasione.

Spessore totale del film secco: 70-80 μm .

CONFORMITÀ A DIRETTIVE E NORME

La progettazione delle gru è conforme alla normativa FEM 1001 relativa alle strutture di acciaio e agli apparecchi di sollevamento.

Le gru a bandiera FAS sono conformi alla Direttiva Macchine 2006/42/CE e vengono consegnate con marcatura CE, Dichiarazione di Conformità e Manuale d'uso e manutenzione.



Gru a bandiera a colonna

Column mounted jib cranes

TIPO C
con braccio in profilato a canalina

C TYPE
with channel profile arm

CARATTERISTICHE SPECIFICATION

The arm, manufactured with a special press-formed channel profile, stable and light, ensures the best swinging sensitivity and sliding of the trolley. The rigid structure of the column ensures the stability of the trolley during all lifting stages.

Available with manual push trolley.

All cranes are supplied complete with power supply line and junction box.

- Arms length from 2 to 8 m.
- Rotation 270°.
- Capacity from 125 to 1,000 kg.

Il braccio, realizzato in uno speciale profilo pressopiegato a canalina, stabile e leggero, garantisce la migliore sensibilità di brandeggio e di scorrevolezza del carrello.

La struttura rigida della colonna assicura la stabilità del carrello durante tutte le fasi del sollevamento.

Disponibile con carrello manuale a spinta.

Tutte le gru vengono fornite complete di linea di alimentazione e cassetta di derivazione.

- Sbracci da 2 a 8 m.
- Rotazione 270°.
- Portate da 125 a 1000 kg.



DATI TECNICI

TECHNICAL DATA

Portata Capacity	Sbraccio Arm length	Gru tipo Crane type	Paranco Kito tipo Kito hoist type	Dimensioni Dimensions								Piastra base per tasselli Base plate for chemical anchors	Piastra base per tirafondi Base plate for long bolts	Peso gru senza paranco Crane weight with no hoist	P*	M*
				H mm	H1 mm	H2 mm	A mm	B mm	C mm	D mm	E mm					
125	2	C 12/2	KQ1S-SD	4065	3500	3605	290	2055	395	385	130	039U06	039U06	220	430	485
125	3	C 12/3	KQ1S-SD	4065	3500	3605	290	3055	395	485	130	039U06	039U06	235	450	725
125	4	C 12/4	KQ1S-SD	4065	3500	3605	290	4055	395	535	130	039U06	039U06	250	465	985
125	5	C 12/5	KQ1S-SD	4065	3500	3605	350	5055	395	595	130	050U08	050U08	334	555	1295
125	6	C 12/6	KQ1S-SD	4065	3500	3605	350	6070	395	665	130	050U08	050U08	359	585	1630
125	7	C 12/7	KQ1S-SD	4075	3265	3382	405	7070	395	725	130	066C10	061F08	494	735	2140
125	8	C 12/8	KQ1S-SD	4075	3265	3415	405	8080	395	840	130	066C10	061F08	574	825	2845
250	2	C 25/2	KQ3S-SD	4065	3500	3605	290	2055	395	385	130	039U06	039U06	220	570	790
250	3	C 25/3	KQ3S-SD	4065	3500	3605	290	3055	395	485	130	039U06	039U06	235	585	1170
250	4	C 25/4	KQ3S-SD	4065	3500	3605	350	4050	395	575	130	050U08	050U08	324	685	1620
250	5	C 25/5	KQ3S-SD	4075	3265	3370	405	5070	395	635	130	066C10	061F08	439	810	2135
250	6	C 25/6	KQ3S-SD	4075	3265	3382	405	6070	395	665	130	066C10	061F08	469	845	2640
250	7	C 25/7	KQ3S-SD	4075	3265	3415	405	7070	395	770	160	066C10	061F08	544	930	3390
250	8	C 25/8	KQ3S-SD	4080	3155	3355	470	8080	395	840	160	072C12	066F08	804	1215	4430
500	2	C 50/2	KQ5S-SD	4065	3500	3650	290	2050	410	385	160	039U06	039U06	225	855	1400
500	3	C 50/3	KQ5S-SD	4065	3500	3650	350	3050	410	570	160	050U08	050U08	309	950	2115
500	4	C 50/4	KQ5S-SD	4075	3265	3415	405	4070	410	640	160	066C10	061F08	454	1110	2985
500	5	C 50/5	KQ5S-SD	4075	3265	3415	405	5070	410	640	160	066C10	061F08	489	1150	3780
500	6	C 50/6	KQ5S-SD	4080	3155	3305	470	6080	410	740	160	072C12	066F08	679	1355	4695
500	7	C 50/7	KQ5S-SD	4080	3155	3305	470	7080	410	770	160	072C12	066F08	714	1395	5570
1000	2	C 100/2	KQ10S-SD	4075	3265	3415	405	2070	465	640	310	066C10	061F08	404	1640	2725
1000	3	C 100/3	KQ10S-SD	4075	3265	3415	405	3070	465	660	310	066C10	061F08	434	1675	4030
1000	4	C 100/4	KQ10S-SD	4080	3155	3305	470	4080	465	740	310	072C12	066F08	619	1880	5480
1000	5	C 100/5	KQ10S-SD	4080	3155	3305	470	5080	465	790	310	090C16	066F08	739	2010	6890
1000	6	C 100/6	KQ10S-SD	4080	3050	3200	565	6100	465	860	310	100C16	080F14	916	2205	8525
1000	7	C 100/7	KQ10S-SD	4080	3050	3250	565	7100	465	920	310	100C12	080F14	976	2270	10120

* Carichi calcolati secondo UNI EN 13001 parti 1 e 2.
I pesi delle gru sono riferiti a colonne alte 4m.
Dimensioni piastre di base e plinti a pagina 250-253.

* Loads calculated according to UNI EN 13001 parts 1 and 2.
Cranes weights referred to 4m column height.
Plinths and base dimensions see page 250-253.

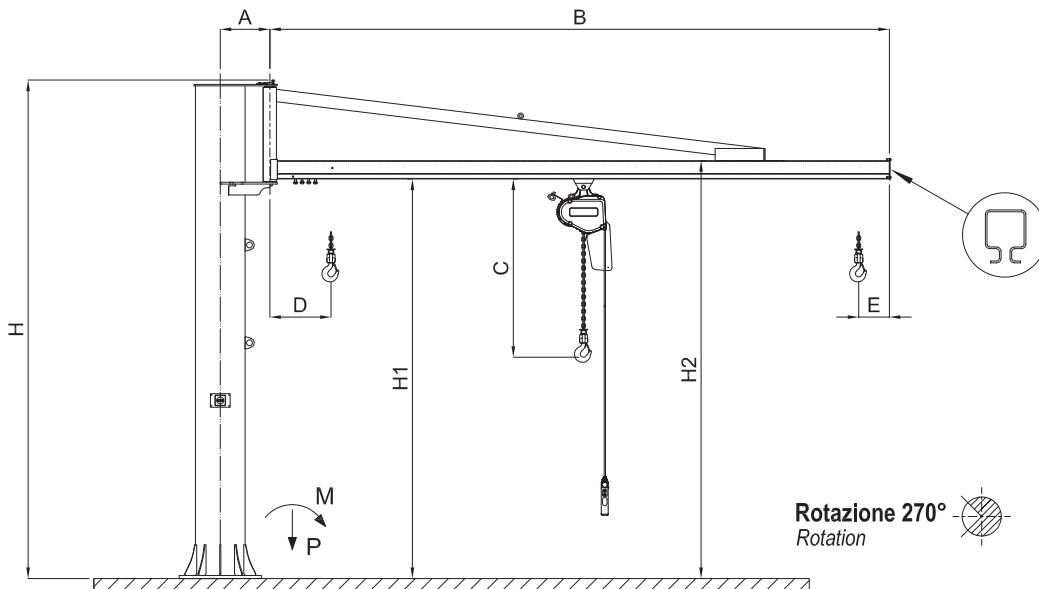

Gru a bandiera a mensola

Wall mounted jib cranes

TIPO M
con braccio in profilato a canalina

M TYPE
with channel profile arm

CARATTERISTICHE SPECIFICATION

The arm is made with a special press-formed channel profile, stable and light and ensures the best swinging sensitivity and sliding of the trolley.

The supporting bracket, tie rods and counter supports are manufactured according to the required dimensions.

Available with manual push trolley.

All cranes are supplied complete with power supply line and junction box.

- Arm length from 2 to 8 m.
- Rotation 270°.
- Capacity from 125 to 1.000 kg.

Il braccio, realizzato in uno speciale profilo pressopiegato a canalina, stabile e leggero, garantisce la migliore sensibilità di brandeggio e di scorrevolezza del carrello.

La mensola di sostegno, i tiranti e le controstaffe vengono costruiti in base alle dimensioni richieste.

Disponibile con carrello manuale a spinta.

Tutte le gru vengono fornite complete di linea di alimentazione e cassetta di derivazione.

- Sbracci da 2 a 8 m.
- Rotazione 270°.
- Portate da 125 a 1000 kg.



DATI TECNICI

TECHNICAL DATA

Portata Capacity	Sbraccio Arm length	Gru tipo Crane type	Paranco Kito tipo Kito hoist type	Dimensioni mensola standard Standard wall bracket dimensions					Dimensioni Dimensions					Tiranti Tie rods	Peso gru senza paranco Crane weight with no hoist	P*	R*	
				Larghezza pilastro Pillar width	H1 mm	H mm	F1 mm	F mm	A mm	B mm	C mm	D mm	E mm					M mm
daN	m			Q max mm											kg	daN	daN	
125	2	M 12/2	KQ1S-SD	300	330	400	655	785	220	2055	395	385	130	640	4 X M18	133	330	725
125	3	M 12/3	KQ1S-SD	300	330	400	655	785	220	3055	395	485	130	640	4 X M18	148	350	1095
125	4	M 12/4	KQ1S-SD	300	330	400	655	785	220	4055	395	535	130	640	4 X M18	163	365	1490
125	5	M 12/5	KQ1S-SD	300	330	400	655	785	220	5055	395	595	130	640	4 X M18	183	385	1930
125	6	M 12/6	KQ1S-SD	300	330	400	655	785	220	6070	395	665	130	640	4 X M18	208	415	2440
125	7	M 12/7	KQ1S-SD	300	330	400	915	1045	280	7070	395	725	130	890	4 X M20	285	500	2305
125	8	M 12/8	KQ1S-SD	300	330	400	915	1045	280	8080	395	840	130	890	4 X M20	368	590	3060
250	2	M 25/2	KQ3S-SD	300	330	400	655	785	220	2055	395	385	130	640	4 X M18	133	470	1180
250	3	M 25/3	KQ3S-SD	300	330	400	655	785	220	3055	395	485	130	640	4 X M18	148	485	1760
250	4	M 25/4	KQ3S-SD	300	330	400	655	785	220	4050	395	575	130	640	4 X M18	173	515	2400
250	5	M 25/5	KQ3S-SD	300	330	400	915	1045	280	5070	395	635	130	890	4 X M20	230	575	2290
250	6	M 25/6	KQ3S-SD	300	330	400	915	1045	280	6070	395	665	130	890	4 X M20	260	610	2835
250	7	M 25/7	KQ3S-SD	300	330	400	915	1045	280	7070	395	770	160	890	4 X M20	338	695	3645
250	8	M 25/8	KQ3S-SD	380	430	500	1040	1195	315	8080	395	840	160	1020	4 X M27	496	870	4180
500	2	M 50/2	KQ5S-SD	300	330	400	655	785	220	2050	410	385	250	640	4 X M18	141	755	2080
500	3	M 50/3	KQ5S-SD	300	330	400	655	785	220	3050	410	570	250	640	4 X M18	161	780	3105
500	4	M 50/4	KQ5S-SD	300	330	400	915	1045	280	4070	410	640	160	890	4 X M20	248	875	3175
500	5	M 50/5	KQ5S-SD	300	330	400	915	1045	280	5070	410	640	160	890	4 X M20	263	915	4040
500	6	M 50/6	KQ5S-SD	380	430	500	1040	1195	315	6080	410	740	160	1020	4 X M27	371	1010	4415
500	7	M 50/7	KQ5S-SD	380	430	500	1040	1195	315	7080	410	770	160	1020	4 X M27	406	1050	5250
1000	2	M 100/2	KQ10S-SD	300	330	400	915	1045	280	2070	465	640	310	890	4 X M20	207	1405	2820
1000	3	M 100/3	KQ10S-SD	300	330	400	915	1045	280	3070	465	660	310	890	4 X M20	237	1440	4240
1000	4	M 100/4	KQ10S-SD	380	430	500	1040	1195	315	4080	465	740	310	1020	4 X M27	320	1530	5095
1000	5	M 100/5	KQ10S-SD	380	430	500	1040	1195	315	5080	465	790	310	1020	4 X M27	360	1575	6440
1000	6	M 100/6	KQ10S-SD	380	435	500	1150	1195	350	6100	465	860	310	1125	4 X M30	460	1685	7180
1000	7	M 100/7	KQ10S-SD	380	435	510	1150	1300	350	7100	465	920	310	1125	4 X M30	520	1750	8555

* Carichi calcolati secondo UNI EN 13001 parti 1 e 2.
 Su richiesta mensole per pilastri con larghezza Q maggiore.
 Per pesi e carichi è stata considerata la mensola idonea ai pilastri di dimensioni maggiori.
 * Loads calculated according to UNI EN 13001 parts 1 and 2.
 Upon demands, cranes for larger pillar width.
 Weights and loads referred to the crane for largest pillar.

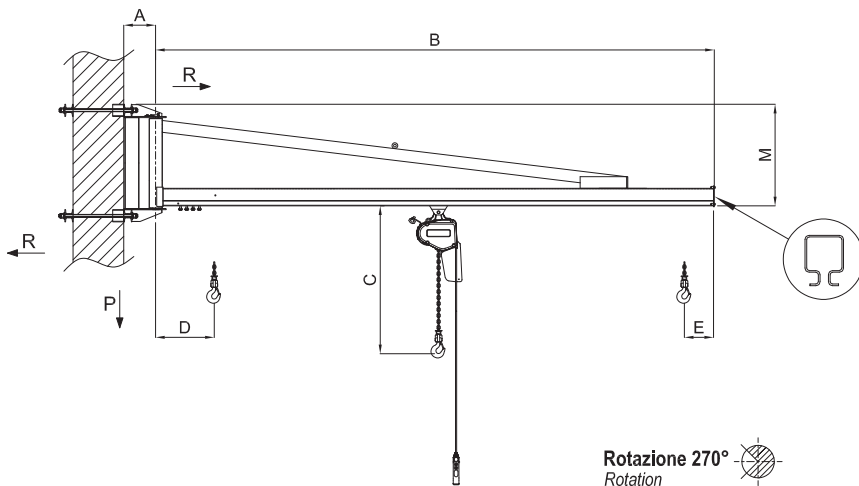

In base alle dimensioni del pilastro
According to the sizes of the pillar

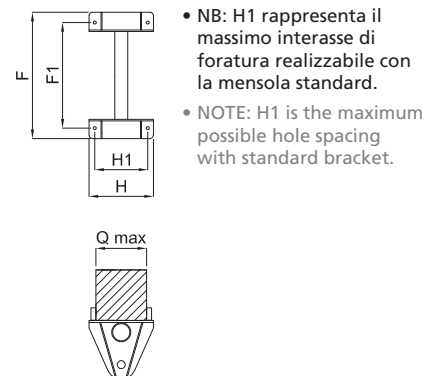

GRU A BANDIERA
JIB CRANES

Gru a bandiera a colonna

Column mounted jib cranes

TIPO CT

con braccio in trave a sbalzo

CT TYPE

with underbraced arm

CARATTERISTICHE

SPECIFICATION

This is an optimal solution where the maximum exploitation of available height is required with further increase of hook travel.

The rigid structure of the column ensures the stability of the trolley in all positions of the jib.

The bearings mounted on the rotation unit allow a smooth rotation.

Available with mechanical, electric or manual push trolley. All cranes are supplied complete with power supply line and junction box.

- Arm length from 2 to 8 m.
- Rotation 270°.
- Capacity from 125 to 2000 kg.

Soluzione ottimale ove si renda necessario il massimo sfruttamento dello spazio disponibile in altezza con conseguente aumento della corsa gancio. La struttura rigida della colonna assicura la stabilità del carrello in tutte le posizioni del braccio.

I cuscinetti montati sul gruppo di rotazione permettono una rotazione senza strappi.

Disponibile con carrello manuale a spinta, meccanico o elettrico.

Tutte le gru vengono fornite complete di linea di alimentazione e cassetta di derivazione.

- Sbracci da 2 a 8 m.
- Rotazione 270°.
- Portate da 125 a 2000 kg.



DATI TECNICI

TECHNICAL DATA

Portata Capacity	Sbraccio Arm length	Gru tipo Crane type	Paranco Kito tipo Kito hoist type	Dimensioni Dimensions										Piastra base per tasselli Base plate for chemical anchors	Piastra base per tirafondi Base plate for long bolts	Peso gru senza paranco Crane weight with no hoist	P*	M*
				H	H1	H2	A	B	C	D	E	N	T					
125	2	CT 12/2	KQ1S-SD	4065	3850	3990	290	2010	415	610	180	140	73	039U06	039U06	220	450	500
125	3	CT 12/3	KQ1S-SD	4065	3830	3990	290	3010	415	695	180	160	82	039U06	039U06	245	475	780
125	4	CT 12/4	KQ1S-SD	4065	3790	3990	290	4010	415	695	180	200	100	039U06	039U06	290	525	1140
125	5	CT 12/5	KQ1S-SD	4065	3770	3990	350	5010	415	950	180	220	110	050U08	050U08	399	645	1570
125	6	CT 12/6	KQ1S-SD	4065	3750	3990	350	6010	415	950	180	240	120	050U08	050U08	454	705	2065
125	7	CT 12/7	KQ1S-SD	4075	3695	3995	405	7010	415	1125	180	300	150	066C10	061F08	659	935	2950
125	8	CT 12/8	KQ1S-SD	4075	3665	3995	405	8010	415	1210	180	330	160	066C10	061F08	759	1045	3830
250	2	CT 25/2	KQ3S-SD	4065	3830	3990	290	2010	415	525	180	160	82	039U06	039U06	227	595	805
250	3	CT 25/3	KQ3S-SD	4065	3790	3990	290	3010	415	695	180	200	100	039U06	039U06	265	640	1255
250	4	CT 25/4	KQ3S-SD	4065	3770	3990	350	4010	415	865	180	220	110	050U08	050U08	369	750	1780
250	5	CT 25/5	KQ3S-SD	4075	3755	3995	405	5010	415	1040	180	240	120	066C10	061F08	519	915	2445
250	6	CT 25/6	KQ3S-SD	4075	3695	3995	405	6010	415	1040	180	300	150	066C10	061F08	624	1035	3290
250	7	CT 25/7	KQ3S-SD	4075	3665	3995	405	7010	415	1125	180	330	160	066C10	061F08	719	1135	4210
250	8	CT 25/8	KQ3S-SD	4080	3635	3995	470	8010	415	1300	180	360	170	072C12	066F08	999	1445	5465
500	2	CT 50/2	KQ5S-SD	4065	3790	3990	290	2010	430	610	180	200	100	039U06	039U06	240	890	1415
500	3	CT 50/3	KQ5S-SD	4065	3770	3990	350	3010	430	865	180	220	110	050U08	050U08	329	1000	2195
500	4	CT 50/4	KQ5S-SD	4075	3725	3995	405	4010	430	955	180	270	135	066C10	061F08	509	1185	3140
500	5	CT 50/5	KQ5S-SD	4075	3695	3995	405	5010	430	1040	180	300	150	066C10	061F08	579	1260	4090
500	6	CT 50/6	KQ5S-SD	4080	3665	3995	470	6010	430	1130	180	330	160	072C12	066F08	829	1535	5295
500	7	CT 50/7	KQ5S-SD	4080	3635	3995	470	7010	430	1215	180	360	170	072C12	066F08	939	1655	6595
500	8	CT 50/8	KQ5S-SD	4080	3595	3995	565	8010	430	1390	180	400	180	100C16	080F14	1301	2055	8340
1000	2	CT 100/2	KQ10S-SD	4075	3775	3995	405	2010	490	880	190	220	110	066C10	061F08	412	1665	2840
1000	3	CT 100/3	KQ10S-SD	4075	3695	3995	405	3010	490	965	190	300	150	066C10	061F08	489	1750	4260
1000	4	CT 100/4	KQ10S-SD	4080	3665	3995	470	4010	490	1055	190	330	160	072C12	066F08	729	2015	5900
1000	5	CT 100/5	KQ10S-SD	4080	3635	3995	470	5010	490	1140	190	360	170	090C16	066F08	904	2205	7565
1000	6	CT 100/6	KQ10S-SD	4080	3595	3995	565	6010	490	1230	190	400	180	100C16	080F14	1164	2495	9625
1000	7	CT 100/7	KQ10S-SD	4080	3545	3995	565	7010	490	1315	190	450	190	100C12	080F14	1311	2655	11760
2000	3	CT 200/3	KRQ20C-CD	4080	3635	3995	470	3010	695	1065	200	360	170	090C16	066F08	782	3215	8225
2000	4	CT 200/4	KRQ20C-CD	4080	3595	3995	565	4010	695	1155	200	400	180	100C12	080F14	1025	3485	11270
2000	5	CT 200/5	KRQ20C-CD	4080	3545	3995	565	5010	695	1240	200	450	190	100C12	080F14	1159	3630	14265

* Carichi calcolati secondo UNI EN 13001 parti 1 e 2.
I pesi delle gru sono riferiti a colonne alte 4m.
Dimensioni piastre di base e plinti a pagina 250-253.

* Loads calculated according to UNI EN 13001 parts 1 and 2.
Cranes weights referred to 4m column height.
Plinths and base dimensions see page 250-253.

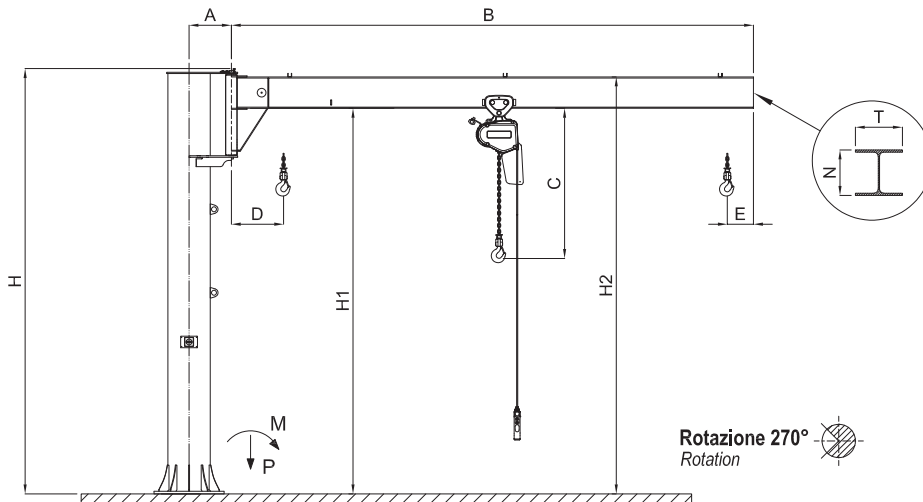

Gru a bandiera a mensola

Wall mounted jib cranes

TIPO MT
con braccio in trave a sbalzo

MT TYPE
with underbraced arm

CARATTERISTICHE SPECIFICATION

This is an optimal solution where the maximum utilization of the available space in height is required with a consequent increase of hook travel.

The structure of the crane and the bearings mounted on the rotating unit ensure trolley stability and ease of swinging.

The supporting bracket, tie rods and counter-supports are manufactured according to the required dimensions.

Available with mechanical, electric or manual push trolley. All cranes are supplied complete with power supply line and junction box.

- Arm length from 2 to 8 m.
- Rotation 270°.
- Capacity from 125 to 2.000 kg.

Soluzione ottimale ove si renda necessario il massimo sfruttamento dello spazio disponibile in altezza con conseguente aumento della corsa gancio.

La struttura della gru e i cuscinetti montati sul gruppo di rotazione garantiscono stabilità del carrello e facilità di brandeggio.

La mensola di sostegno, i tiranti e le controstaffe vengono costruiti in base alle dimensioni richieste.

Disponibile con carrello manuale a spinta, meccanico o elettrico.

Tutte le gru vengono fornite complete di linea di alimentazione e cassetta di derivazione.

- Sbracci da 2 a 8 m.
- Rotazione 270°.
- Portate da 125 a 2000 kg.



DATI TECNICI

TECHNICAL DATA

Portata Capacity	Sbraccio Arm length	Gru tipo Crane type	Paranco Kito tipo Kito hoist type	Dimensioni mensola standard Standard wall bracket dimensions					Dimensioni Dimensions									Tiranti Tie rods	Peso gru senza paranco Crane weight with no hoist	P*	R*
				Larghezza pilastro Pillar width	Q max mm	H1 mm	H mm	F1 mm	F mm	A mm	B mm	C mm	D mm	E mm	M mm	N mm	T mm				
125	2	MT 12/2	KQ1S-SD	300	330	400	655	785	220	2010	415	610	180	310	140	73	4 X M18	129	350	755	
125	3	MT 12/3	KQ1S-SD	300	330	400	655	785	220	3010	415	695	180	330	160	82	4 X M18	154	375	1175	
125	4	MT 12/4	KQ1S-SD	300	330	400	655	785	220	4010	415	695	180	370	200	100	4 X M18	199	425	1715	
125	5	MT 12/5	KQ1S-SD	300	330	400	655	785	220	5010	415	950	180	390	220	110	4 X M18	244	475	2335	
125	6	MT 12/6	KQ1S-SD	300	330	400	655	785	220	6010	415	950	180	410	240	120	4 X M18	299	535	3080	
125	7	MT 12/7	KQ1S-SD	300	330	400	915	1045	280	7010	415	1125	180	470	300	150	4 X M20	446	700	3165	
125	8	MT 12/8	KQ1S-SD	300	330	400	915	1045	280	8010	415	1210	180	500	330	160	4 X M20	546	810	4105	
250	2	MT 25/2	KQ3S-SD	300	330	400	655	785	220	2010	415	525	180	350	160	82	4 X M18	136	495	1200	
250	3	MT 25/3	KQ3S-SD	300	330	400	655	785	220	3010	415	695	180	370	200	100	4 X M18	174	540	1880	
250	4	MT 25/4	KQ3S-SD	300	330	400	655	785	220	4010	415	865	180	390	220	110	4 X M18	214	580	2630	
250	5	MT 25/5	KQ3S-SD	300	330	400	915	1045	280	5010	415	1040	180	410	240	120	4 X M20	306	685	2610	
250	6	MT 25/6	KQ3S-SD	300	330	400	915	1045	280	6010	415	1040	180	470	300	150	4 X M20	411	800	3525	
250	7	MT 25/7	KQ3S-SD	300	330	400	915	1045	280	7010	415	1125	180	500	330	160	4 X M20	506	905	4515	
250	8	MT 25/8	KQ3S-SD	380	430	500	1040	1195	315	8010	415	1300	180	550	360	170	4 X M27	684	1100	5145	
500	2	MT 50/2	KQ5S-SD	300	330	400	655	785	220	2010	430	610	180	350	200	100	4 X M18	149	765	2030	
500	3	MT 50/3	KQ5S-SD	300	330	400	655	785	220	3010	430	865	180	390	220	110	4 X M18	174	810	3115	
500	4	MT 50/4	KQ5S-SD	300	330	400	915	1045	280	4010	430	955	180	440	270	135	4 X M20	296	925	3235	
500	5	MT 50/5	KQ5S-SD	300	330	400	915	1045	280	5010	430	1040	180	470	300	150	4 X M20	366	1005	4240	
500	6	MT 50/6	KQ5S-SD	380	430	500	1040	1195	315	6010	430	1130	180	520	330	160	4 X M27	514	1165	4835	
500	7	MT 50/7	KQ5S-SD	380	430	500	1040	1195	315	7010	430	1215	180	550	360	170	4 X M27	624	1310	6200	
500	8	MT 50/8	KQ5S-SD	380	435	510	1150	1300	350	8010	430	1390	180	590	400	180	4 X M30	829	1535	7040	
1000	2	MT 100/2	KQ10S-SD	300	330	400	915	1045	280	2070	490	880	190	410	220	110	4 X M20	199	1430	3025	
1000	3	MT 100/3	KQ10S-SD	300	330	400	915	1045	280	3070	490	965	190	470	300	150	4 X M20	276	1515	4570	
1000	4	MT 100/4	KQ10S-SD	380	430	500	1040	1195	315	4080	490	1055	190	520	330	160	4 X M27	414	1670	5570	
1000	5	MT 100/5	KQ10S-SD	380	430	500	1040	1195	315	5080	490	1140	190	550	360	170	4 X M27	509	1770	7155	
1000	6	MT 100/6	KQ10S-SD	380	435	510	1150	1300	350	6100	490	1230	190	590	400	180	4 X M30	692	1975	8195	
1000	7	MT 100/7	KQ10S-SD	380	435	510	1150	1300	350	7010	490	1315	190	640	450	190	4 X M30	839	2135	9905	
2000	3	MT 200/3	KRQ20C-CD	380	430	500	1040	1195	315	3010	695	980	200	550	360	170	4 X M27	387	2780	7550	
2000	4	MT 200/4	KRQ20C-CD	380	435	510	1150	1300	350	4010	695	1155	200	590	400	180	4 X M30	553	2965	9325	
2000	5	MT 200/5	KRQ20C-CD	380	435	510	1150	1300	350	5010	695	1240	200	640	450	190	4 X M30	687	3110	11900	

* Carichi calcolati secondo UNI EN 13001 parti 1 e 2.

Su richiesta mensole per pilastri con larghezza Q maggiore.

Per pesi e carichi è stata considerata la mensola idonea ai pilastri di dimensioni maggiori.

* Loads calculated according to UNI EN 13001 parts 1 and 2.

Upon demands, cranes for larger pillar width.

Weights and loads referred to the crane for largest pillar.

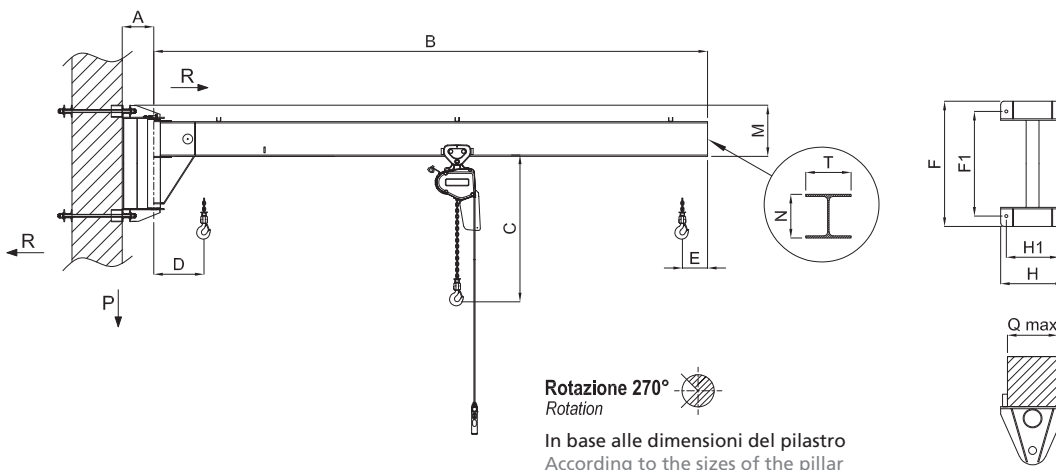

Gru a bandiera a colonna

Column mounted jib cranes

TIPO C2T
con braccio in trave con tiranti

C2T TYPE
with overbraced arm

CARATTERISTICHE SPECIFICATION

The column-mounted cranes with tie beam arm ensure ease of swinging and trolley stability even in case of significant capacity and long jibs. The rotation unit is always mounted on bearings.

Available with mechanical, electric or manual push trolley. All cranes are supplied complete with power supply line and junction box.

- Arm length from 3 to 8 m.
- Rotation 270°.
- Capacity from 250 to 2,000 kg.

Le gru a colonna con braccio in trave con uno o due tiranti assicurano facilità nel brandeggio e stabilità del carrello anche in presenza di portate e bracci notevoli.

Il gruppo di rotazione è sempre montato su cuscinetti.

Disponibili con carrello manuale a spinta, meccanico o elettrico.

Tutte le gru vengono fornite complete di linea di alimentazione e cassetta di derivazione.

- Sbracci da 3 a 8 m.
- Rotazione 270°.
- Portate da 250 a 2000 kg.



DATI TECNICI

TECHNICAL DATA

Portata Capacity	Sbraccio Arm length	Gru tipo Crane type	Paranco Kito tipo Kito hoist type	Dimensioni Dimensions										Piastra base per tasselli Base plate for chemical anchors	Piastra base per tirafondi Base plate for long bolts	Peso gru senza paranco Crane weight with no hoist	P*	M*						
				H	H1	H2	A	B	C	D	E	N	T											
daN	m			mm	mm	mm	mm	mm	mm	mm	mm	mm	mm	mm	mm	mm	mm	mm	mm	mm	mm	kg	daN	daNxm
250	4	C2T 25/4	KQ3S-SD	4065	3490	3630	350	4010	415	865	180	140	73	050U08	050U08	359	740	1750						
250	5	C2T 25/5	KQ3S-SD	4075	3235	3395	405	5010	415	1040	180	160	82	066C10	061F08	482	875	2330						
250	6	C2T 25/6	KQ3S-SD	4075	3275	3415	405	6010	415	1040	180	140	140	066C10	061F08	537	935	2965						
250	7	C2T 25/7	KQ3S-SD	4075	3275	3415	405	7010	415	1125	180	140	140	066C10	061F08	569	970	3565						
250	8	C2T 25/8	KQ3S-SD	4080	3165	3325	470	8010	415	1300	180	160	160	072C12	066F08	822	1250	4595						
500	2	C2T 50/2	KQ5S-SD	4065	3490	3630	290	2010	430	610	180	140	73	039U06	039U06	235	885	1410						
500	3	C2T 50/3	KQ5S-SD	4065	3490	3630	350	3010	430	865	180	140	73	050U08	050U08	327	985	2160						
500	4	C2T 50/4	KQ5S-SD	4075	3235	3395	405	4010	430	955	180	160	82	066C10	061F08	456	1125	3000						
500	5	C2T 50/5	KQ5S-SD	4075	3275	3415	405	5010	430	1040	180	140	140	066C10	061F08	512	1185	3875						
500	6	C2T 50/6	KQ5S-SD	4080	3165	3305	470	6010	430	1130	180	140	140	072C12	066F08	704	1400	4815						
500	7	C2T 50/7	KQ5S-SD	4080	3165	3305	470	7010	430	1215	180	140	140	072C12	066F08	736	1435	5710						
500	8	C2T 50/8	KQ5S-SD	4080	3060	3220	565	8010	430	1390	180	160	160	100C16	080F14	1051	1780	7080						
1000	3	C2T 100/3	KQ10S-SD	4075	3275	3415	405	3015	490	970	190	140	140	066C10	061F08	446	1705	4180						
1000	4	C2T 100/4	KQ10S-SD	4080	3165	3325	405	4015	490	1140	190	160	160	072C12	066F08	660	1940	5720						
1000	5	C2T 100/5	KQ10S-SD	4080	3165	3325	470	5015	490	1190	190	160	160	090C16	066F08	797	2090	7220						
1000	6	C2T 100/6	KQ10S-SD	4080	3060	3220	470	6015	490	1190	190	160	160	100C16	080F14	969	2280	8865						
1000	7	C2T 100/7	KQ10S-SD	4080	3060	3240	565	7015	490	1190	190	180	180	100C12	080F14	1076	2395	10715						
1000	8	C2T 100/8	KQ10S-SD	4080	3060	3240	565	8015	490	1190	190	180	180	100C12	080F14	1125	2450	12385						
2000	3	C2T 200/3	KRQ20C-CD	4080	3165	3345	470	3010	695	1065	200	180	180	090C16	066F08	741	3170	8140						
2000	4	C2T 200/4	KRQ20C-CD	4080	3060	3240	565	4010	695	1155	200	180	180	100C12	080F14	927	3375	11005						
2000	5	C2T 200/5	KRQ20C-CD	4080	3060	3240	565	5010	695	1240	200	180	180	100C12	080F14	985	3440	13690						
2000	6	C2T 200/6	KRQ20C-CD	4080	2810	3010	565	6010	695	1240	200	200	200	-	080F14	1052	3515	16625						
2000	7	C2T 200/7	KRQ20C-CD	4080	2810	3030	565	7010	695	1325	200	220	220	-	080F14	1165	3635	19710						

* Carichi calcolati secondo UNI EN 13001 parti 1 e 2.
I pesi delle gru sono riferiti a colonne alte 4m.
Dimensioni piastre di base e plinti a pagina 250-253.

* Loads calculated according to UNI EN 13001 parts 1 and 2.
Cranes weights referred to 4m column height.
Plinths and base dimensions see page 250-253.

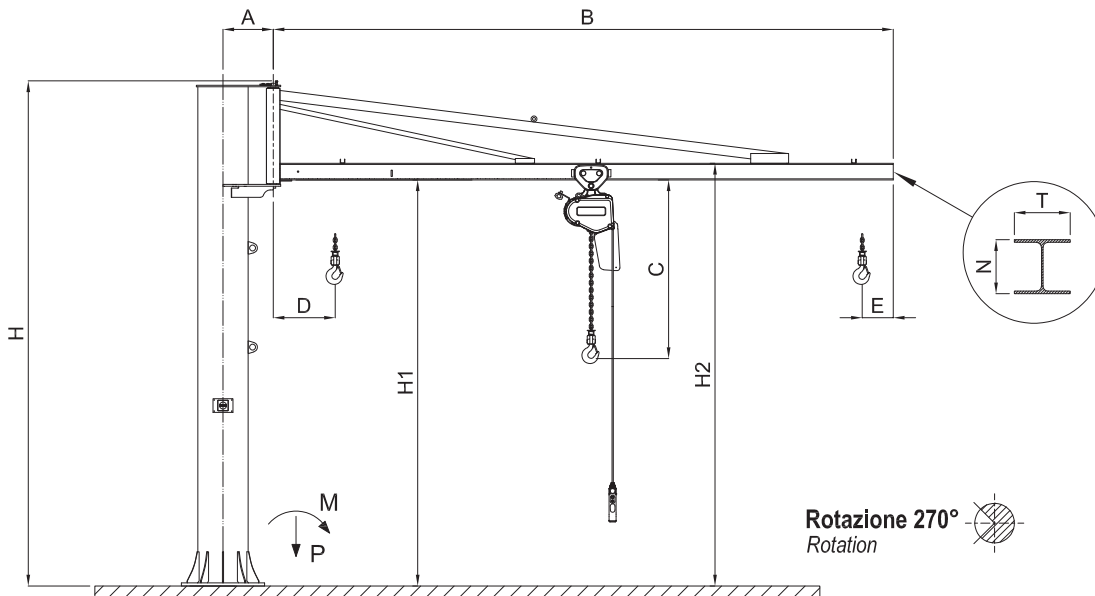

Gru a bandiera a mensola

Wall mounted jib cranes

TIPO M2T
con braccio in trave con tiranti

M2T TYPE
with overbraced arm

CARATTERISTICHE SPECIFICATION

The wall mounted cranes with tie beam arm ensure ease of swinging and trolley stability also in case of significant capacity and long jibs. The rotation unit is always mounted on bearings.

Available with mechanical, electric or manual push trolley. All cranes are supplied complete with power supply line and junction box.

- Arm length from 3 to 8 m.
- Rotation 270°.
- Capacity from 250 to 2.000 kg.

Le gru a mensola con braccio in trave con uno o due tiranti assicurano facilità nel brandeggio e stabilità del carrello anche in presenza di portate e bracci notevoli.

Il gruppo di rotazione è sempre montato su cuscinetti.

Disponibili con carrello manuale a spinta, meccanico o elettrico.

Tutte le gru vengono fornite complete di linea di alimentazione e cassetta di derivazione.

- Sbracci da 3 a 8 m.
- Rotazione 270°.
- Portate da 250 a 2000 kg.



DATI TECNICI

TECHNICAL DATA

Portata Capacity	Sbraccio Arm length	Gru tipo Crane type	Paranco Kito tipo Kito hoist type	Dimensioni mensola standard Standard wall bracket dimensions					Dimensioni Dimensions									Tiranti Tie rods	Peso gru senza paranco Crane weight with no hoist	P*	R*
				Larghezza pilastro Pillar width	H1 mm	H mm	F1 mm	F mm	A mm	B mm	C mm	D mm	E mm	M mm	N mm	T mm					
daN	m			Q max mm														kg	daN	daN	
250	4	M2T 25/4	KQ3S-SD	300	330	400	655	785	220	4010	415	865	180	880	140	73	4 X M18	204	570	2595	
250	5	M2T 25/5	KQ3S-SD	300	330	400	915	1045	280	5010	415	1040	180	880	160	82	4 X M20	269	640	2490	
250	6	M2T 25/6	KQ3S-SD	300	330	400	915	1045	280	6010	415	1040	180	880	140	140	4 X M20	324	705	3180	
250	7	M2T 25/7	KQ3S-SD	300	330	400	915	1045	280	7010	415	1125	180	880	140	140	4 X M20	356	740	3830	
250	8	M2T 25/8	KQ3S-SD	380	430	500	1040	1195	315	8010	415	1300	180	1010	160	160	4 X M27	507	905	4335	
500	2	M2T 50/2	KQ5S-SD	300	330	400	655	785	220	2010	430	610	180	630	140	73	4 X M18	144	760	2020	
500	3	M2T 50/3	KQ5S-SD	300	330	400	655	785	220	3010	430	865	180	630	140	73	4 X M18	172	790	3070	
500	4	M2T 50/4	KQ5S-SD	300	330	400	915	1045	280	4010	430	955	180	880	160	82	4 X M20	243	870	3090	
500	5	M2T 50/5	KQ5S-SD	300	330	400	915	1045	280	5010	430	1040	180	880	140	140	4 X M20	299	930	4015	
500	6	M2T 50/6	KQ5S-SD	380	430	500	1040	1195	315	6010	430	1130	180	1010	140	140	4 X M27	389	1030	4395	
500	7	M2T 50/7	KQ5S-SD	380	430	500	1040	1195	315	7010	430	1215	180	1010	140	140	4 X M27	421	1085	5375	
500	8	M2T 50/8	KQ5S-SD	380	435	510	1150	1300	350	8010	430	1390	180	1120	160	160	4 X M30	579	1260	6000	
1000	3	M2T 100/3	KQ10S-SD	300	330	400	915	1045	280	3070	490	965	190	880	140	140	4 X M20	233	1470	4475	
1000	4	M2T 100/4	KQ10S-SD	380	430	500	1040	1195	315	4080	490	1055	190	1010	160	160	4 X M27	345	1590	5395	
1000	5	M2T 100/5	KQ10S-SD	380	430	500	1040	1195	315	5080	490	1140	190	1040	160	160	4 X M27	402	1655	6830	
1000	6	M2T 100/6	KQ10S-SD	380	435	510	1150	1300	350	6100	490	1230	190	1120	160	160	4 X M30	497	1760	7560	
1000	7	M2T 100/7	KQ10S-SD	380	435	510	1150	1300	350	7010	490	1315	190	1120	180	180	4 X M30	604	1875	9035	
1000	8	M2T 100/8	KQ10S-SD	380	435	510	1150	1300	350	8010	490	1400	190	1120	180	180	4 X M30	653	1930	10485	
2000	3	M2T 200/3	KRQ20C-CD	380	430	500	1040	1195	315	3010	695	980	200	1010	180	180	4 X M27	346	2735	7470	
2000	4	M2T 200/4	KRQ20C-CD	380	435	510	1150	1300	350	4010	695	1155	200	1120	180	180	4 X M30	455	2855	9105	
2000	5	M2T 200/5	KRQ20C-CD	380	435	510	1150	1300	350	5010	695	1240	200	1120	180	180	4 X M30	513	2920	11425	
2000	6	M2T 200/6	KRQ20C-CD	430	485	560	1400	1550	350	6010	695	1240	200	1365	200	200	4 X M33	632	3050	11470	
2000	7	M2T 200/7	KRQ20C-CD	430	485	560	1400	1550	350	7010	695	1325	200	1365	220	220	4 X M33	745	3175	13650	

* Carichi calcolati secondo UNI EN 13001 parti 1 e 2.
 Su richiesta mensole per pilastri con larghezza Q maggiore.
 Per pesi e carichi è stata considerata la mensola idonea al pilastro di dimensioni maggiori.

* Loads calculated according to UNI EN 13001 parts 1 and 2.
 Upon demands, cranes for larger pillar width.
 Weights and loads referred to the crane for largest pillar.

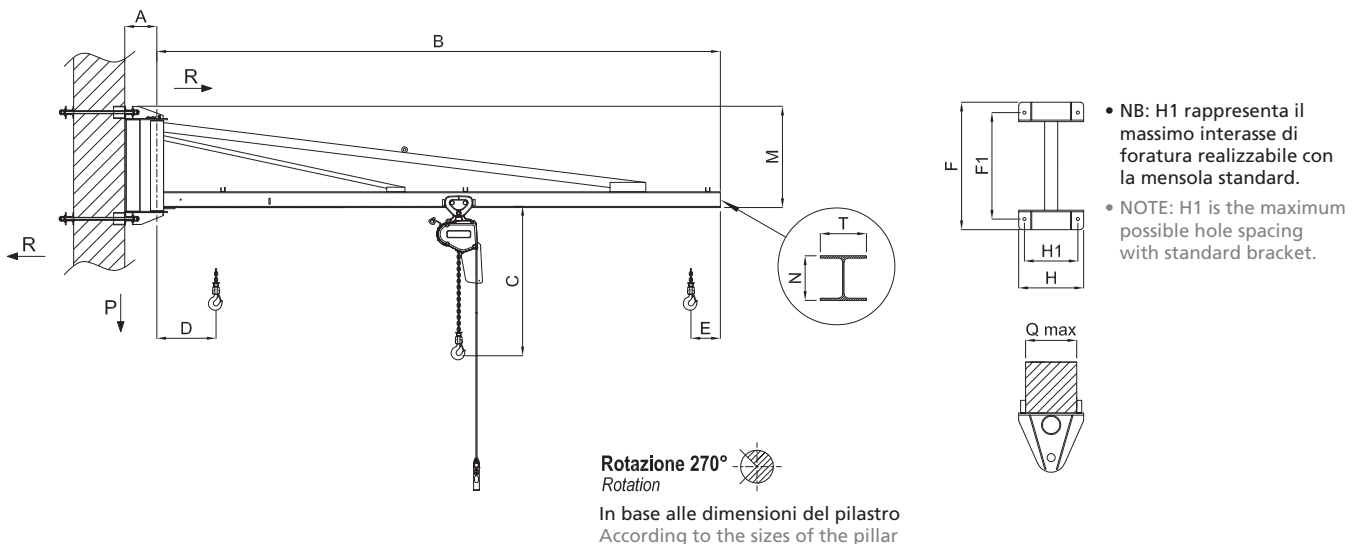

Gru a bandiera a colonna

Column mounted jib cranes

TIPO CS

con braccio snodato con paranco scorrevole o fisso in punta

CS TYPE
with articulated arm
with sliding or fixed hoist

DATI TECNICI

TECHNICAL DATA

The jib cranes with articulated arm allow to reach corners of the work area where, due to obstacles, it would be otherwise impossible with a standard rigid jib. The jib consists of two segments swiveling on bearings, rotating independently one from the other. The first segment of the jib, close to the column, is usually manufactured with hollow box, the second one with a double-T beam. There are no ties on the jib to allow exploiting all the available height. The hoist is usually supplied mounted on the tip of the arm; on request it can be mounted on a trolley. - Arm length from 2 to 8 m. - Rotation: First jib rotation 240°, Second jib rotation 300°. - Capacity from 250 to 1000 kg.

Le gru a bandiera con braccio snodato permettono di raggiungere quei punti dell'area di lavoro dove, a causa di ostacoli, sarebbe impossibile arrivare con il normale braccio rigido. Il braccio è composto da due segmenti girevoli su cuscinetti in grado di ruotare in maniera indipendente uno dall'altro. Il primo segmento del braccio, a ridosso della colonna, viene generalmente realizzato in cassone, il secondo in trave a doppio T. Non sono previsti tiranti sopra il braccio per permettere di sfruttare tutta l'altezza possibile. Il paranco viene normalmente fornito montato fisso in punta al braccio; su richiesta può essere montato su carrello. - Sbracci da 2 a 8 m. - Rotazione: Primo braccio 240°, Secondo braccio 300°. - Portate da 250 a 1000 kg.

Portata Capacity	Sbraccio Arm length	Gru tipo Crane type	Paranco Kito tipo Kito hoist type	Dimensioni Dimensions									Piastra base per tasselli Base plate for chemical anchors	Piastra base per tirafondi Base plate for long bolts	Peso gru senza paranco Crane weight with no hoist	P*	M*
				H mm	H1 mm	H2 mm	A mm	B mm	B1 mm	Paranco scorrevole Sliding hoist	Paranco fisso in punta Fixed hoist at the tip	T mm					
250	4	CS 25/2+2	KQ3S-SD	4065	3760	3740	350	2000	2000	415	395	82	050U08	050U08	384	770	1835
250	5	CS 25/2+3	KQ3S-SD	4075	3720	3690	405	2000	3000	415	395	100	066C10	061F08	539	940	2500
250	6	CS 25/3+3	KQ3S-SD	4075	3720	3690	405	3000	3000	415	395	100	066C10	061F08	659	1070	3350
250	7	CS 25/3+4	KQ3S-SD	4075	3700	3590	405	3000	4000	415	395	110	066C10	061F08	759	1180	4270
250	8	CS 25/4+4	KQ3S-SD	4080	3700	3590	470	4000	4000	415	395	110	072C12	066F08	1054	1505	5525
500	5	CS 50/2+3	KQ5S-SD	4075	3700	3590	405	2000	3000	430	410	110	066C10	061F08	609	1295	4195
500	6	CS 50/3+3	KQ5S-SD	4080	3720	3590	470	3000	3000	430	410	120	072C12	066F08	869	1580	5400
500	7	CS 50/3+4	KQ5S-SD	4080	3690	3590	470	3000	4000	430	410	135	072C12	066F08	989	1710	6700
500	8	CS 50/4+4	KQ5S-SD	4080	3660	3490	565	4000	4000	430	410	150	100C16	080F14	1366	2125	8440
1000	4	CS 100/2+2	KQ10S-SD	4080	3720	3590	470	2000	2000	490	465	120	072C12	066F08	759	2045	6115
1000	5	CS 100/2+3	KQ10S-SD	4080	3660	3490	470	2000	3000	490	465	150	090C16	066F08	944	2250	7780
1000	6	CS 100/3+3	KQ10S-SD	4080	3660	3490	565	3000	3000	490	465	150	100C16	080F14	1216	2550	9840

* Carichi calcolati secondo UNI EN 13001 parti 1 e 2.
I pesi delle gru sono riferiti a colonne alte 4m.
Dimensioni piastre di base e plinti a pagina 250-253.

* Loads calculated according to UNI EN 13001 parts 1 and 2.
Cranes weights referred to 4m column height.
Plinths and base dimensions see page 250-253.

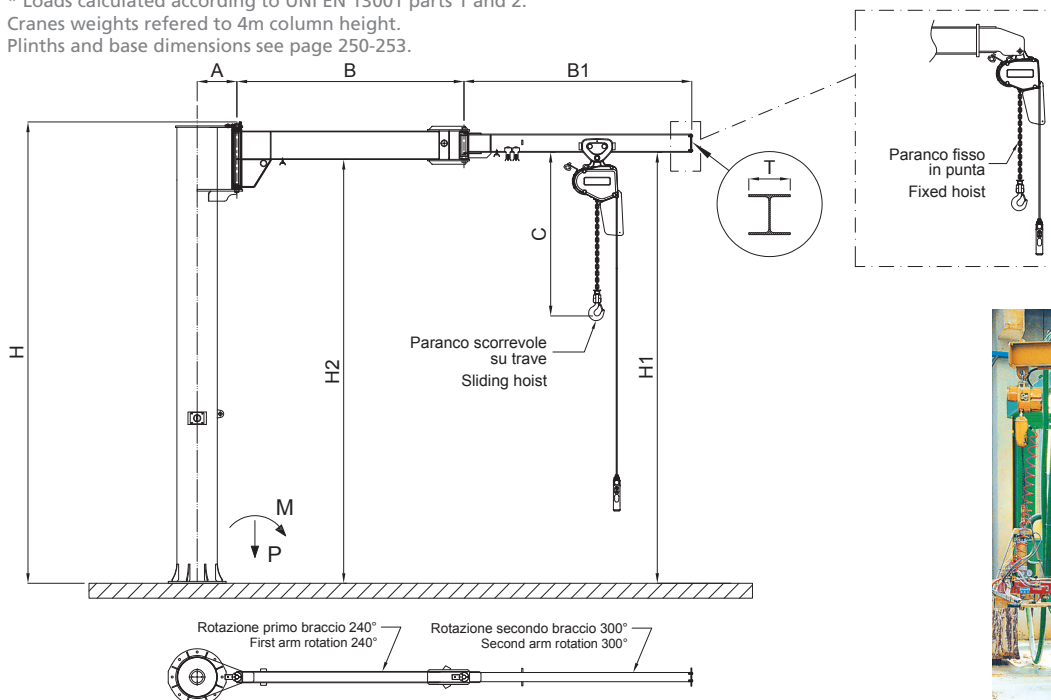

Gru a bandiera a mensola

Wall mounted jib cranes

TIPO MS

con braccio snodato con paranco scorrevole o fisso in punta

MS TYPE
with articulated arm
with sliding or fixed hoist

DATI TECNICI

TECHNICAL DATA

The jib cranes with articulated arm allow to reach corners of the work area where, due to obstacles, it would be otherwise impossible with a standard rigid jib.

The jib consists of two segments swiveling on bearings, rotating independently one from the other.

The first segment of the jib, close to the column, is usually manufactured with hollow box, the second one with a double-T beam.

There are no ties on the jib to allow exploiting all the available height.

The hoist is usually supplied mounted on the tip of the arm; on request it can be mounted on a trolley.

- Arm length from 2 to 8 m.
- Rotation: First jib rotation 240°, Second jib rotation 300°.
- Capacity from 250 to 1000 kg.

Le gru a bandiera con braccio snodato permettono di raggiungere quei punti dell'area di lavoro dove, a causa di ostacoli, sarebbe impossibile arrivare con il normale braccio rigido.

Il braccio è composto da due segmenti girevoli su cuscinetti in grado di ruotare in maniera indipendente uno dall'altro.

Il primo segmento del braccio, a ridosso della colonna, viene generalmente realizzato in cassone, il secondo in trave a doppio T.

Non sono previsti tiranti sopra il braccio per permettere di sfruttare tutta l'altezza possibile.

Il paranco viene normalmente fornito montato fisso in punta al braccio; su richiesta può essere montato su carrello.

- Sbracci da 2 a 8 m.
- Rotazione: Primo braccio 240°, Secondo braccio 300°.
- Portate da 250 a 1000 kg.

Portata Capacity	Sbraccio Arm length	Gru tipo Crane type	Paranco Kito tipo Kito hoist type	Dimensioni mensola standard Standard wall bracket dimensions							Dimensioni Dimensions				Tiranti Tie rods	Peso gru senza paranco Crane weight with no hoist	P*	R*
				Larghezza pilastro Pillar width	Q max mm	H1 mm	H mm	F1 mm	F mm	A mm	B mm	B1 mm	Paranco scorrevole Sliding hoist	Paranco fisso in punta Fixed hoist at the tip				
250	4	MS 25/2+2	KQ3S-SD	300	330	400	655	785	220	2000	2000	415	395	M18	229	600	2775	
250	5	MS 25/2+3	KQ3S-SD	300	330	400	915	1045	280	2000	3000	415	395	M20	326	705	2780	
250	6	MS 25/3+3	KQ3S-SD	300	330	400	915	1045	280	3000	3000	415	395	M20	446	835	3725	
250	7	MS 25/3+4	KQ3S-SD	300	330	400	915	1045	280	3000	4000	415	395	M20	546	945	4760	
250	8	MS 25/4+4	KQ3S-SD	380	430	500	1040	1195	315	4000	4000	415	395	M27	739	1160	5450	
500	5	MS 50/2+3	KQ5S-SD	300	330	400	915	1045	280	2000	3000	430	410	M20	396	1035	4450	
500	6	MS 50/3+3	KQ5S-SD	380	430	500	1040	1195	315	3000	3000	430	410	M27	554	1210	5070	
500	7	MS 50/3+4	KQ5S-SD	380	430	500	1040	1195	315	3000	4000	430	410	M27	674	1365	6500	
500	8	MS 50/4+4	KQ5S-SD	380	435	510	1150	1300	350	4000	4000	430	410	M30	894	1605	7400	
1000	4	MS 100/2+2	KQ10S-SD	380	430	500	1040	1195	315	2000	2000	490	465	M27	444	1700	5760	
1000	5	MS 100/2+3	KQ10S-SD	380	430	500	1040	1195	315	2000	3000	490	465	M27	549	1815	7390	
1000	6	MS 100/3+3	KQ10S-SD	380	435	510	1150	1300	350	3000	3000	490	465	M30	744	2030	8435	

* Carichi calcolati secondo UNI EN 13001 parti 1 e 2.

Su richiesta mensole per pilastri con larghezza Q maggiore.

Per pesi e carichi è stata considerata la mensola idonea al pilastro di dimensioni maggiori.

* Loads calculated according to UNI EN 13001 parts 1 and 2.

Upon demands, cranes for larger pillar width.

Weights and loads referred to the crane for largest pillar.

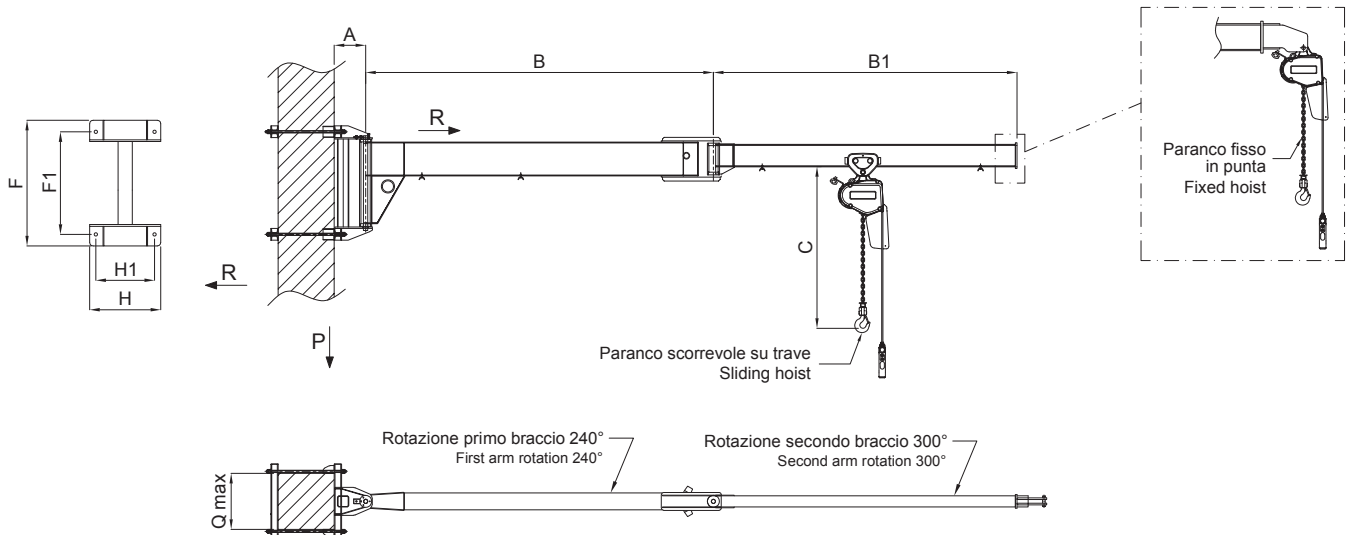

Gru a bandiera a colonna

Column mounted jib cranes

TIPO RE
rotazione elettrica 360°

RE TYPE
electric rotation 360°

CARATTERISTICHE SPECIFICATION

The jib cranes with 360° electric rotation are the solution to handle very heavy loads for the full range of the crane, when the standard cranes with 270° rotation are insufficient.

The column is made of folded and ribbed sheet metal with flange drilled for fastening to a bearing wheel in the upper section and with drilled frame at the bottom for fastening to the floor using anchor bolts.

The jib is manufactured with beams or hollow box, depending on its length and capacity and it is mounted on a revolving wheel through a self braking gear-motor with soft start and braking.

The cranes are supplied with a single electrical panel containing contactors controlling all movements, or with two separate control panels, one for operating the hoist trolley and the other for the rotation of the jib.

The power supply runs through a conduit while the push-button can be supplied hanged to the hoist or sliding independently.

Capacities from 1000 kg to 10 ton.

Le gru a bandiera con rotazione elettrica 360° rappresentano la soluzione per movimentare carichi, in genere molto pesanti, per tutto il raggio di azione della gru, quando le classiche gru con rotazione 270° non sono sufficienti.

La colonna portante è realizzata in lamiera d'acciaio piegata e nervata, con flangia forata per il fissaggio della ralla nella parte superiore e con piastra forata nella parte inferiore per il fissaggio al basamento tramite tirafondi.

Il braccio viene realizzato in trave o in cassone in funzione della lunghezza e della portata ed è montato su una ralla girevole mediante motoriduttore autofrenante con avviamento e frenata progressivi.

Le gru vengono fornite con un unico quadro elettrico contenente i teleruttori per tutti i movimenti o con due quadri elettrici separati, uno per il comando del paranco carrello e l'altro per la rotazione del braccio.

Il cavo di alimentazione scorre in una canalina mentre la pulsantiera può essere fornita pendente dal paranco o indipendente dallo stesso.

Portate da 1000 kg a 10 ton.



Gru a bandiera a colonna

Column mounted jib cranes

TIPO RE

con braccio in trave o in cassone
rotazione elettrica 360°

RE TYPE
with beam or box arm
electric rotation 360°

DATI TECNICI

TECHNICAL DATA

Portata Capacity	Braccio Arm length	Gru tipo Crane type	Paranco Kito tipo Kito hoist type	Dimensioni Dimensions						Velocità di rotazione Rotation speed	Piastra base per tirafondi Base plate for long bolts	Tirafondi Tie rods	Peso gru senza paranco Crane weight with no hoist	P	M
				H mm	H1 mm	B mm	C mm	N mm	T mm						
1000	4	RE 100/4	KRR10L/3	4000	3700	4000	435	300	150	0,77	800 x 800	8 x M24	1105	2737	6850
1000	5	RE 100/5	KRR10L/3	4000	3670	5000	435	330	160	0,59	800 x 800	8 x M27	1170	2800	8800
1000	6	RE 100/6	KRR10L/3	4000	3640	6000	435	360	170	0,50	800 x 800	8 x M30	1410	3040	11100
1000	7	RE 100/7	KRR10L/3	4000	3600	7000	435	400	190	0,43	900 x 900	12 x M27	1700	3340	13500
1000	8	RE 100/8	KRR10L/3	4000	3400	8000	435	600	300	0,38	900 x 900	12 x M27	2070	3720	16500
1000	9	RE 100/9	KRR10L/3	4000	3350	9000	435	650	300	0,32	900 x 900	12 x M30	2300	3960	19100
2000	4	RE 200/4	KRR20L/3	4000	3640	4000	570	360	170	0,77	800 x 800	8 x M30	1220	4220	11850
2000	5	RE 200/5	KRR20L/3	4000	3600	5000	570	400	190	0,59	900 x 900	12 x M27	1510	4515	15450
2000	6	RE 200/6	KRR20L/3	4000	3400	6000	570	600	300	0,50	1100 x 1100	12 x M30	1810	4830	19150
2000	7	RE 200/7	KRR20L/3	4000	3350	7000	570	650	300	0,43	1100 x 1100	12 x M30	2110	5140	23130
2000	8	RE 200/8	KRR20L/3	4000	3300	8000	570	700	300	0,38	1100 x 1100	12 x M30	2750	5790	27810
3200	4	RE 320/4	KRR32S/3	4000	3400	4000	765	600	300	0,77	900 x 900	12 x M30	1610	6122	17370
3200	5	RE 320/5	KRR32S/3	4000	3350	5000	765	650	300	0,59	1100 x 1100	12 x M30	1940	6460	22620
3200	6	RE 320/6	KRR32S/3	4000	3300	6000	765	700	300	0,50	1200 x 1200	16 x M27	2370	6890	28160
3200	7	RE 320/7	KRR32S/3	4000	3250	7000	765	750	300	0,43	1200 x 1200	16 x M30	2990	7500	33700
3200	8	RE 320/8	KRR32S/3	4000	3200	8000	765	800	300	0,38	1200 x 1200	16 x M33	3470	8000	40350
5000	4	RE 500/4	KRR50S/3	4000	3250	4000	840	750	300	0,77	1200 x 1200	16 x M27	2175	9000	26300
5000	5	RE 500/5	KRR50S/3	4000	3200	5000	840	800	300	0,59	1200 x 1200	16 x M30	2765	9600	33830
5000	6	RE 500/6	KRR50S/3	4000	3150	6000	840	850	300	0,50	1400 x 1400	20 x M30	3185	10040	41720
5000	7	RE 500/7	KRR50S/3	4000	3100	7000	840	900	300	0,43	1400 x 1400	20 x M30	3550	10400	50280

* Carichi calcolati secondo UNI EN 13001 parti 1 e 2.
Loads calculated according to UNI EN 13001 parts 1 and 2.

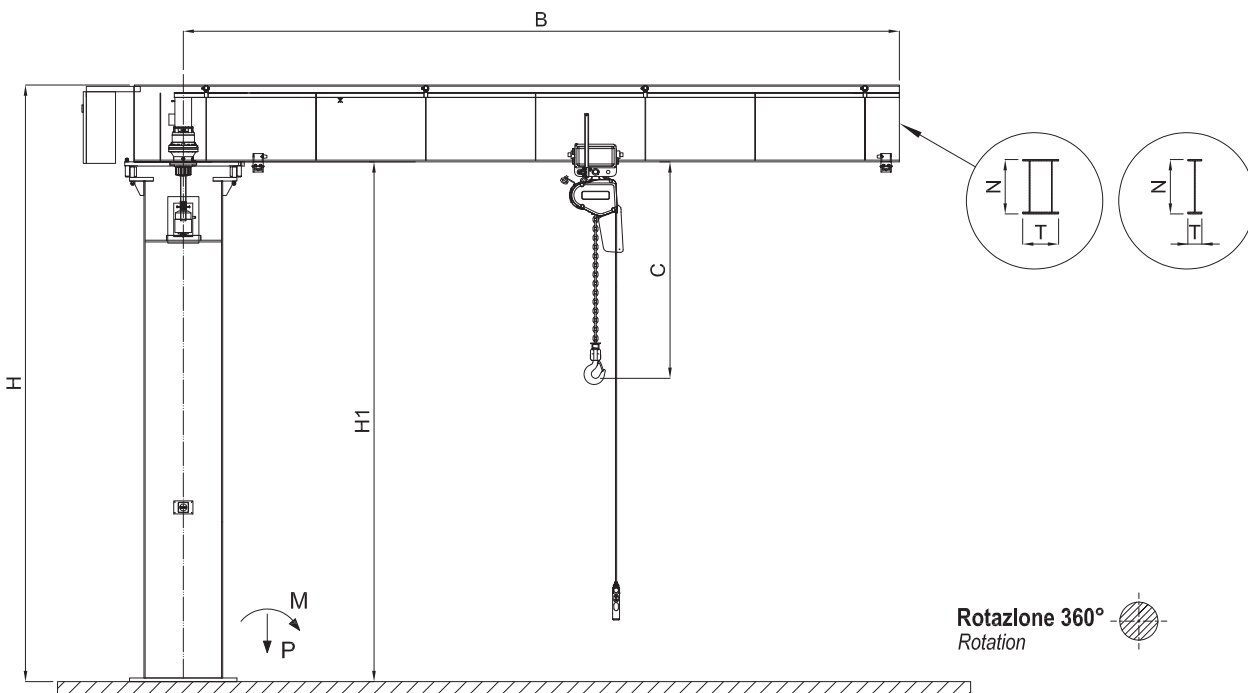

GRU A BANDIERA
JIB CRANES

Gru a bandiera a colonna

Column mounted jib cranes

TIPO RM

con braccio in trave a sbalzo
rotazione manuale 360°

RM TYPE
with underbraced arm
manual rotation 360°

DATI TECNICI

TECHNICAL DATA

Portata Capacity	Braccio Arm length	Gru tipo Crane type	Paranco Kito tipo hoist type	Dimensioni Dimensions								Piastra base per tasselli Base plate for chemical anchors		Piastra base per tirafondi Base plate for long bolts		Peso gru senza paranco Crane weight with no hoist	P	M
				H mm	H1 mm	B mm	C mm	D mm	E mm	N mm	T mm	Dim. Dim.	N° N°	Dim. Dim.	N° N°			
500	3	RM 50/3	KQ5S-SD	4000	3780	3000	430	910	180	220	110	540 x 540	8 x M16	540 x 540	8 x M20	430	1000	2195
500	4	RM 50/4	KQ5S-SD	4000	3760	4000	430	910	180	240	120	700 x 700	12 x M16	540 x 540	8 x M20	540	1190	3140
500	5	RM 50/5	KQ5S-SD	4000	3730	5000	430	910	180	270	150	800 x 800	16 x M16	700 x 700	8 x M24	650	1260	4080
500	6	RM 50/6	KQ5S-SD	4000	3700	6000	430	910	180	300	160	800 x 800	16 x M16	700 x 700	8 x M24	780	1530	5290
500	7	RM 50/7	KQ5S-SD	4000	3670	7000	430	910	180	330	170	800 x 800	16 x M16	800 x 800	8 x M24	990	1650	6590
1000	3	RM 100/3	KQ10S-SD	4000	3730	3000	490	920	180	270	150	800 x 800	16 x M16	700 x 700	8 x M27	680	2600	5600
1000	4	RM 100/4	KQ10S-SD	4000	3700	4000	490	920	180	300	160	800 x 800	16 x M16	700 x 700	8 x M27	780	2730	6850
1000	5	RM 100/5	KQ10S-SD	4000	3670	5000	490	920	180	330	170	1000 x 1000	16 x M16	800 x 800	8 x M27	980	2800	8800
1000	6	RM 100/6	KQ10S-SD	4000	3640	6000	490	920	180	360	180	1000 x 1000	16 x M16	800 x 800	8 x M27	1130	3030	11100
1000	7	RM 100/7	KQ10S-SD	4000	3600	7000	490	920	180	400	200	1000 x 1000	16 x M20	900 x 900	12 x M27	1350	3330	13500
2000	3	RM 200/3	KRQ20C-CD	4000	3640	3000	695	930	180	360	180	1000 x 1000	16 x M16	800 x 800	8 x M27	750	3950	9600
2000	4	RM 200/4	KRQ20C-CD	4000	3600	4000	695	930	180	400	200	1000 x 1000	16 x M20	800 x 800	8 x M27	870	4200	11850
2000	5	RM 200/5	KRQ20C-CD	4000	3600	5000	695	930	180	400	200	1000 x 1000	16 x M20	900 x 900	12 x M27	1010	4500	15450

* Carichi calcolati secondo UNI EN 13001 parti 1 e 2.
Loads calculated according to UNI EN 13001 parts 1 and 2.

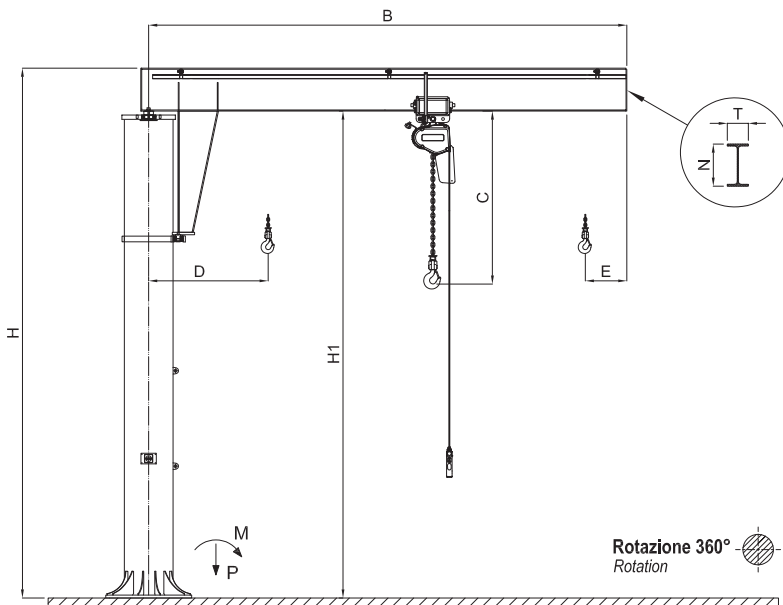

Gru a bandiera a colonna

Column mounted jib cranes

TIPO CTE

con braccio in trave a sbalzo
rotazione elettrica 270°

CTE TYPE
with underbraced arm
electric rotation 270°

CARATTERISTICHE

SPECIFICATION

The rotation of the jib occurs through a system of gear-motor-joint coupled directly to the pivot pin and it is regulated by an inverter; it is equipped with an epicyclic reduction and driven by an electric self-braking motor with a soft start. The push-button is supplied hanging from the hoist or sliding independently, as needed.

La rotazione del braccio avviene mediante un sistema motoriduttore-giunto accoppiato direttamente al perno di rotazione ed è regolata tramite inverter; il riduttore è di tipo epicicloidale ed è azionato da un motore elettrico autofrenante con avviamento progressivo. La pulsantiera viene fornita pendente dal paranco o scorrevole indipendente in canalina, in base alle necessità.

DATI TECNICI

TECHNICAL DATA

Portata Capacity	Sbraccio Arm length	Gru tipo Crane type	Paranco Kito tipo Kito hoist type	Dimensioni Dimensions										Velocità di rotazione Rotation speed	Piastra base per tasselli Base plate for chemical anchors		Piastra base per tirafondi Base plate for long bolts		P*	M*
				H mm	H1 mm	A mm	B mm	C mm	D mm	E mm	N mm	T mm	rpm		Dim. Dim.	N° N°	Dim. Dim.	N° N°		
250	4	CTE 25/4	KQ3S-SD	4000	3730	350	4000	415	865	180	220	110	0,77	540 x 540	8 x M16	540 x 540	8 x M20	830	2290	
250	5	CTE 25/5	KQ3S-SD	4000	3710	400	5000	415	1040	180	240	120	0,59	700 x 700	12 x M16	540 x 540	8 x M20	1000	3030	
250	6	CTE 25/6	KQ3S-SD	4000	3650	400	6000	415	1040	180	300	150	0,50	700 x 700	12 x M16	540 x 540	8 x M24	1110	4030	
250	7	CTE 25/7	KQ3S-SD	4000	3620	400	7000	415	1125	180	330	160	0,43	800 x 800	16 x M16	700 x 700	8 x M24	1310	5160	
250	8	CTE 25/8	KQ3S-SD	4000	3590	400	8000	415	1300	180	360	170	0,38	800 x 800	16 x M16	700 x 700	8 x M24	1470	6500	
500	3	CTE 50/3	KQ5S-SD	4000	3730	400	3000	430	865	180	220	110	1,00	540 x 540	8 x M16	540 x 540	8 x M20	1200	2910	
500	4	CTE 50/4	KQ5S-SD	4000	3710	400	4000	430	955	180	240	120	0,77	700 x 700	12 x M16	540 x 540	8 x M20	1310	3970	
500	5	CTE 50/5	KQ5S-SD	4000	3650	400	5000	430	1040	180	300	150	0,59	800 x 800	16 x M16	700 x 700	8 x M24	1500	5270	
500	6	CTE 50/6	KQ5S-SD	4000	3620	400	6000	430	1130	180	330	160	0,50	800 x 800	16 x M16	700 x 700	8 x M24	1650	6650	
500	7	CTE 50/7	KQ5S-SD	4000	3590	500	7000	430	1215	180	360	170	0,43	800 x 800	16 x M16	800 x 800	8 x M24	1920	8310	
500	8	CTE 50/8	KQ5S-SD	4000	3550	500	8000	430	1390	180	400	180	0,38	1000 x 1000	16 x M20	800 x 800	8 x M27	2090	10100	
1000	3	CTE 100/3	KQ10S-SD	4000	3680	500	3000	490	965	190	270	135	1,00	800 x 800	16 x M16	700 x 700	8 x M27	2170	5510	
1000	4	CTE 100/4	KQ10S-SD	4000	3620	500	4000	490	1055	190	330	160	0,77	800 x 800	16 x M16	700 x 700	8 x M27	2300	7540	
1000	5	CTE 100/5	KQ10S-SD	4000	3590	500	5000	490	1140	190	360	170	0,59	1000 x 1000	16 x M16	800 x 800	8 x M27	2590	9780	
1000	6	CTE 100/6	KQ10S-SD	4000	3550	500	6000	490	1230	190	400	180	0,50	1000 x 1000	16 x M16	800 x 800	8 x M27	2780	11950	
1000	7	CTE 100/7	KQ10S-SD	4000	3500	600	7000	490	1315	190	450	190	0,43	1000 x 1000	16 x M20	900 x 900	12 x M27	3070	14910	
2000	3	CTE 200/3	KRQ20C-CD	4000	3590	600	3000	695	1065	200	360	170	1,00	1000 x 1000	16 x M16	800 x 800	8 x M27	3980	10720	
2000	4	CTE 200/4	KRQ20C-CD	4000	3550	600	4000	695	1155	200	400	180	0,77	1000 x 1000	16 x M20	800 x 800	8 x M27	4220	14500	
2000	5	CTE 200/5	KRQ20C-CD	4000	3500	600	5000	695	1240	200	450	190	0,59	1000 x 1000	16 x M20	900 x 900	12 x M27	4370	18280	

Velocità periferica di rotazione all'estremità del braccio 18m/min circa.
Rotation speed at the tip of the arm B: about 18m/min.

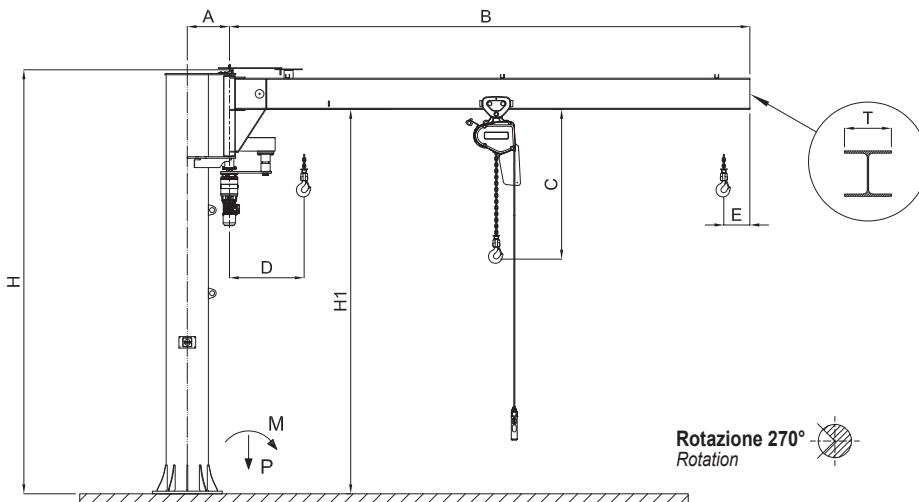

Gru a bandiera a colonna

Column mounted jib cranes

TIPO C2TE

con braccio in trave con tiranti
rotazione elettrica 270°

C2TE TYPE
with overbraced arm
electric rotation 270°

CARATTERISTICHE

SPECIFICATION

The rotation of the jib occurs through a system of gear-motor-joint coupled directly to the pivot pin and it is regulated by an inverter; it is equipped with an epicyclic reduction and driven by an electric self-braking motor with a soft start. The push-button is supplied hanging from the hoist or sliding independently, as needed.

La rotazione del braccio avviene mediante un sistema motoriduttore-giunto accoppiato direttamente al perno di rotazione ed è regolata tramite inverter; il riduttore è di tipo epicicloidale ed è azionato da un motore elettrico autofrenante con avviamento progressivo. La pulsantiera viene fornita pendente dal paranco o scorrevole indipendente in canalina, in base alle necessità.

DATI TECNICI

TECHNICAL DATA

Portata Capacity	Sbraccio Arm length	Gru tipo Crane type	Paranco Kito tipo Kito hoist type	Dimensioni Dimensions										Velocità di rotazione Rotation speed	Piastra base per tasselli Base plate for chemical anchors		Piastra base per tirafondi Base plate for long bolts		p*	M*
				H	H1	A	B	C	D	E	N	T	Dim.		N°	Dim.	N°	daN		
250	4	C2TE 25/4	KQ3S-SD	4000	3450	350	4000	415	1040	180	133	140	0,77	540 x 540	8 x M16	540 x 540	8 x M20	840	1960	
250	5	C2TE 25/5	KQ3S-SD	4000	3250	400	5000	415	1040	180	133	140	0,59	700 x 700	12 x M16	540 x 540	8 x M20	930	2440	
250	6	C2TE 25/6	KQ3S-SD	4000	3250	400	6000	415	1040	180	133	140	0,50	700 x 700	12 x M16	700 x 700	8 x M24	1070	2920	
250	7	C2TE 25/7	KQ3S-SD	4000	3150	400	7000	415	1125	180	133	140	0,43	800 x 800	16 x M16	700 x 700	8 x M24	1160	3400	
250	8	C2TE 25/8	KQ3S-SD	4000	3050	400	8000	415	1300	180	152	160	0,38	800 x 800	16 x M16	700 x 700	8 x M24	1220	3880	
500	3	C2TE 50/3	KQ5S-SD	4000	3250	400	3000	430	865	180	133	140	1,00	700 x 700	12 x M16	540 x 540	8 x M20	1210	2700	
500	4	C2TE 50/4	KQ5S-SD	4000	3250	400	4000	430	955	180	133	140	0,77	700 x 700	12 x M16	540 x 540	8 x M20	1310	3580	
500	5	C2TE 50/5	KQ5S-SD	4000	3250	400	5000	430	1040	180	133	140	0,59	800 x 800	16 x M16	700 x 700	8 x M24	1450	4460	
500	6	C2TE 50/6	KQ5S-SD	4000	3150	400	6000	430	1130	180	133	140	0,50	800 x 800	16 x M16	700 x 700	8 x M24	1590	5330	
500	7	C2TE 50/7	KQ5S-SD	4000	3050	500	7000	430	1215	180	152	160	0,43	800 x 800	16 x M16	700 x 700	8 x M24	1820	6240	
500	8	C2TE 50/8	KQ5S-SD	4000	3050	500	8000	430	1390	180	152	160	0,38	1000 x 1000	16 x M20	800 x 800	8 x M27	1870	7100	
1000	3	C2TE 100/3	KQ10S-SD	4000	3150	500	3000	490	965	190	152	160	1,00	800 x 800	16 x M16	700 x 700	8 x M27	2270	5250	
1000	4	C2TE 100/4	KQ10S-SD	4000	3150	500	4000	490	1055	190	152	160	0,77	800 x 800	16 x M16	700 x 700	8 x M27	2300	6900	
1000	5	C2TE 100/5	KQ10S-SD	4000	3050	500	5000	490	1140	190	152	160	0,59	1000 x 1000	16 x M16	700 x 700	8 x M27	2500	8640	
1000	6	C2TE 100/6	KQ10S-SD	4000	3050	500	6000	490	1230	190	152	160	0,50	1000 x 1000	16 x M16	800 x 800	8 x M27	2600	10300	
1000	7	C2TE 100/7	KQ10S-SD	4000	3050	600	7000	490	1315	190	171	180	0,43	1000 x 1000	16 x M20	900 x 900	12 x M27	2870	12040	
1000	8	C2TE 100/8	KQ10S-SD	4000	2950	600	8000	490	1400	190	171	180	0,38	1000 x 1000	16 x M20	900 x 900	12 x M27	2940	13690	
2000	3	C2TE 200/3	KRQ20C-CD	4000	3070	500	3000	695	1065	200	180	180	1,00	1000 x 1000	16 x M16	800 x 800	8 x M27	4080	10240	
2000	4	C2TE 200/4	KRQ20C-CD	4000	3050	600	4000	695	1155	200	180	180	0,77	1000 x 1000	16 x M20	800 x 800	8 x M27	4300	13570	
2000	5	C2TE 200/5	KRQ20C-CD	4000	3050	600	5000	695	1240	200	180	180	0,59	1000 x 1000	16 x M20	900 x 900	12 x M27	4270	16750	

Velocità periferica di rotazione all'estremità del braccio 18m/min circa.
Rotation speed at the tip of the arm B: about 18m/min.

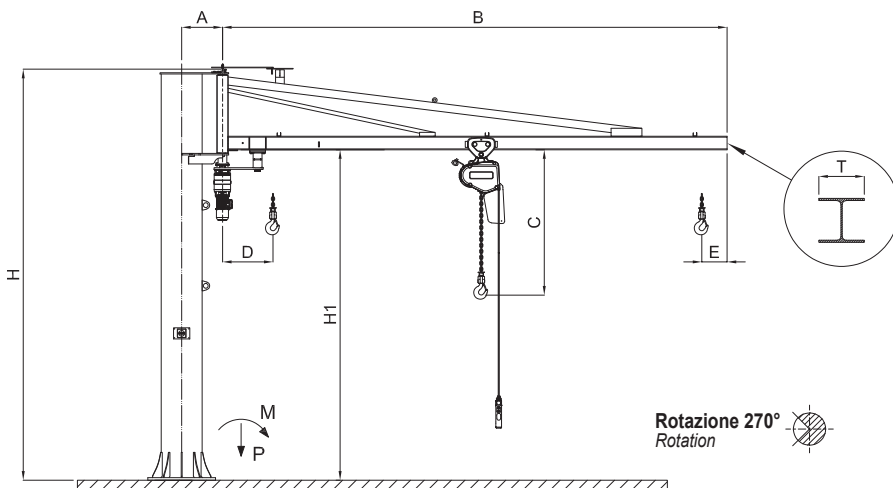

Gru a bandiera a mensola

Wall mounted jib cranes

TIPO MTE

con braccio in trave a sbalzo
rotazione elettrica 270°

MTE TYPE

with underbraced arm
electric rotation 270°

CARATTERISTICHE SPECIFICATION

The rotation of the jib occurs through a system of gear-motor-joint coupled directly to the pivot pin and it is regulated by an inverter; it is equipped with an epicyclic reduction and driven by an electric self-braking motor with a soft start. The push-button is supplied hanging from the hoist or sliding independently, as needed.

La rotazione del braccio avviene mediante un sistema motoriduttore-giunto accoppiato direttamente al perno di rotazione ed è regolata tramite inverter; il riduttore è di tipo epicicloidale ed è azionato da un motore elettrico autofrenante con avviamento progressivo. La pulsantiera viene fornita pendente dal paranco o scorrevole indipendente in canalina, in base alle necessità.

DATI TECNICI TECHNICAL DATA

Portata Capacity	Braccio Arm length	Gru tipo Crane type	Paranco Kito tipo Kito hoist type	Larghezza pilastro std Std pillar width	Dimensioni mensola standard Standard wall bracket dimen- sions				Dimensioni Dimensions							Velocità di rotazione Rotation speed	Tiranti Tie rods	P	M
					Q max mm	H1 mm	H mm	F1 mm	F mm	A mm	B mm	C mm	D mm	E mm	N mm				
250	4	MTE 25/4	KQ3S-SD	300	330	420	735	895	230	4000	415	865	180	220	110	0,77	4 x M20	720	2290
250	5	MTE 25/5	KQ3S-SD	300	330	420	935	1095	230	5000	415	1040	180	240	120	0,59	4 x M20	810	3030
250	6	MTE 25/6	KQ3S-SD	300	330	420	935	1095	230	6000	415	1040	180	300	150	0,50	4 x M24	930	4030
250	7	MTE 25/7	KQ3S-SD	300	330	420	1035	1195	230	7000	415	1125	180	330	160	0,43	4 x M24	1070	5160
250	8	MTE 25/8	KQ3S-SD	300	330	420	1135	1295	230	8000	415	1300	180	360	170	0,38	4 x M24	1220	6500
500	3	MTE 50/3	KQ5S-SD	300	330	420	935	1095	230	3000	430	865	180	220	110	1,00	4 x M24	1100	2910
500	4	MTE 50/4	KQ5S-SD	300	330	420	935	1095	230	4000	430	955	180	240	120	0,77	4 x M24	1150	3970
500	5	MTE 50/5	KQ5S-SD	300	330	420	935	1095	230	5000	430	1040	180	300	150	0,59	4 x M24	1270	5270
500	6	MTE 50/6	KQ5S-SD	300	330	420	1035	1195	230	6000	430	1130	180	330	160	0,50	4 x M27	1400	6650
500	7	MTE 50/7	KQ5S-SD	300	330	420	1135	1295	230	7000	430	1215	180	360	170	0,43	4 x M27	1540	8310
500	8	MTE 50/8	KQ5S-SD	300	330	420	1135	1295	230	8000	430	1390	180	400	180	0,38	4 x M27	1710	10100
1000	3	MTE 100/3	KQ10S-SD	300	330	420	1035	1195	230	3000	490	965	190	270	135	1,00	4 x M27	1940	5540
1000	4	MTE 100/4	KQ10S-SD	300	330	420	1035	1195	230	4000	490	1055	190	330	160	0,77	4 x M27	2060	7540
1000	5	MTE 100/5	KQ10S-SD	300	330	420	1135	1295	230	5000	490	1140	190	360	170	0,59	4 x M27	2220	9780
1000	6	MTE 100/6	KQ10S-SD	300	330	420	1135	1295	230	6000	490	1230	190	400	180	0,50	4 x M30	2320	11950
1000	7	MTE 100/7	KQ10S-SD	300	330	420	1135	1295	230	7000	490	1315	190	450	190	0,43	4 x M30	2550	14910
1000	8	MTE 100/8	KQ10S-SD	300	330	420	1135	1295	230	8000	490	1315	190	500	200	0,4	4 x M30	2800	18000
2000	3	MTE 200/3	KRQ20C-CD	300	330	420	1135	1295	230	3000	695	980	200	360	170	1,00	4 x M30	3590	10720
2000	4	MTE 200/4	KRQ20C-CD	300	330	420	1135	1295	230	4000	695	1155	200	400	180	0,77	4 x M30	3710	14500
2000	5	MTE 200/5	KRQ20C-CD	300	330	420	1135	1295	230	5000	695	1240	200	450	190	0,59	4 x M30	3860	18280

Velocità periferica di rotazione all'estremità del braccio 18m/min circa.
Rotation speed at the tip of the arm B: about 18m/min.

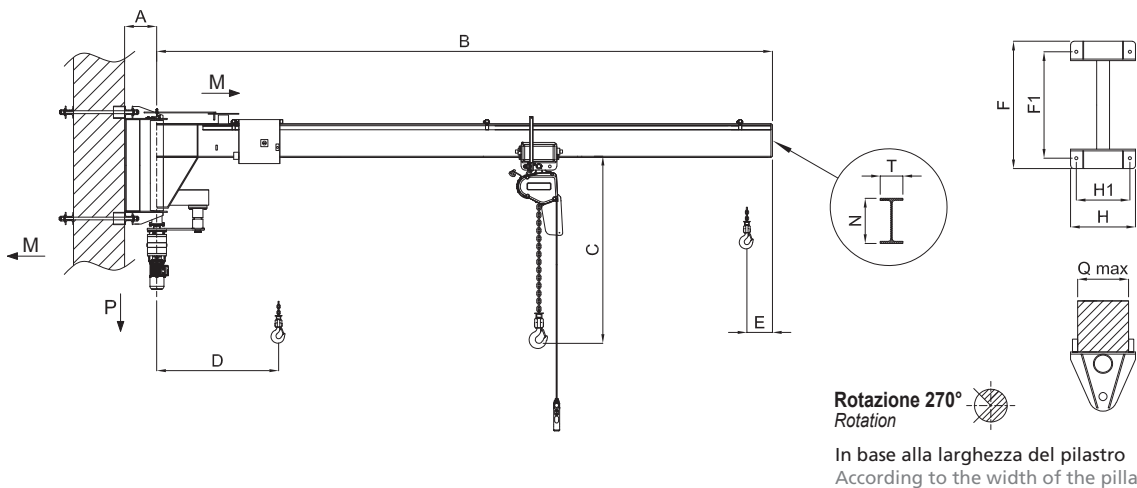

Gru a bandiera a mensola

Wall mounted jib cranes

TIPO M2TE

con braccio in trave con tiranti
rotazione elettrica 270°

M2TE TYPE

with overbraced arm
electric rotation 270°

CARATTERISTICHE SPECIFICATION

The rotation of the jib occurs through a system of gear-motor-joint coupled directly to the pivot pin and it is regulated by an inverter; it is equipped with an epicyclic reduction and driven by an electric self-braking motor with a soft start. The push-button is supplied hanging from the hoist or sliding independently, as needed.

La rotazione del braccio avviene mediante un sistema motoriduttore-giunto accoppiato direttamente al perno di rotazione ed è regolata tramite inverter; il riduttore è di tipo epicicloidale ed è azionato da un motore elettrico autofrenante con avviamento progressivo. La pulsantiera viene fornita pendente dal paranco o scorrevole indipendente in canalina, in base alle necessità.

DATI TECNICI TECHNICAL DATA

Portata Capacity	Braccio Arm length	Gru tipo Crane type	Paranco Kito tipo Kito hoist type	Larghezza pilastro std Std pillar width	Dimensioni mensola standard Standard wall bracket dimen- sions				Dimensioni Dimensions							Velocità di rotazione Rotation speed	Tiranti Tie rods	P	M
					Q max mm	H1 mm	H mm	F1 mm	F mm	A mm	B mm	C mm	D mm	E mm	N mm				
250	5	M2TE 25/5	KQ3S-SD	300	330	420	935	1095	230	5000	415	1040	180	133	140	0,59	4 x M20	780	2440
250	6	M2TE 25/6	KQ3S-SD	300	330	420	935	1095	230	6000	415	1040	180	133	140	0,50	4 x M20	820	2920
250	7	M2TE 25/7	KQ3S-SD	300	330	420	1035	1195	230	7000	415	1125	180	133	140	0,43	4 x M24	860	3400
250	8	M2TE 25/8	KQ3S-SD	300	330	420	1135	1295	230	8000	415	1300	180	152	160	0,38	4 x M24	970	3880
500	3	M2TE 50/3	KQ5S-SD	300	330	420	935	1095	230	3000	430	865	180	133	140	1,00	4 x M24	1090	2700
500	4	M2TE 50/4	KQ5S-SD	300	330	420	935	1095	230	4000	430	955	180	133	140	0,77	4 x M24	1130	3580
500	5	M2TE 50/5	KQ5S-SD	300	330	420	935	1095	230	5000	430	1040	180	133	140	0,59	4 x M24	1170	4460
500	6	M2TE 50/6	KQ5S-SD	300	330	420	1035	1195	230	6000	430	1130	180	133	140	0,50	4 x M27	1250	5330
500	7	M2TE 50/7	KQ5S-SD	300	330	420	1135	1295	230	7000	430	1215	180	152	160	0,43	4 x M27	1300	6230
500	8	M2TE 50/8	KQ5S-SD	300	330	420	1135	1295	230	8000	430	1390	180	152	160	0,38	4 x M27	1340	7100
1000	3	M2TE 100/3	KQ10S-SD	300	330	420	1035	1195	230	3000	490	965	190	152	160	1,00	4 x M27	1930	5250
1000	4	M2TE 100/4	KQ10S-SD	300	330	420	1035	1195	230	4000	490	1055	190	152	160	0,77	4 x M27	1980	6900
1000	5	M2TE 100/5	KQ10S-SD	300	330	420	1135	1295	230	5000	490	1140	190	152	160	0,59	4 x M27	1940	8640
1000	6	M2TE 100/6	KQ10S-SD	300	330	420	1135	1295	230	6000	490	1230	190	152	160	0,50	4 x M30	2120	10300
1000	7	M2TE 100/7	KQ10S-SD	300	330	420	1135	1295	230	7000	490	1315	190	171	180	0,43	4 x M30	2230	12040
1000	8	M2TE 100/8	KQ10S-SD	300	330	420	1235	1395	230	8000	490	1400	190	171	180	0,38	4 x M30	2300	13690
2000	3	M2TE 200/3	KRQ20C-CD	300	330	420	1135	1295	230	3000	695	980	200	160	160	1,00	4 x M30	3590	10240
2000	4	M2TE 200/4	KRQ20C-CD	300	330	420	1135	1295	230	4000	695	1155	200	180	180	0,77	4 x M30	3670	13570
2000	5	M2TE 200/5	KRQ20C-CD	300	330	420	1135	1295	230	5000	695	1240	200	180	180	0,59	4 x M30	3820	16750
2000	6	M2TE 200/6	KRQ20C-CD	300	350	420	1235	1395	230	6000	695	1240	200	200	200	0,50	4 x M33	3920	20090
2000	7	M2TE 200/7	KRQ20C-CD	300	350	420	1435	1595	230	7000	695	1325	200	200	200	0,43	4 x M33	4020	23270

Velocità periferica di rotazione all'estremità del braccio 18m/min circa.
Rotation speed at the tip of the arm B: about 18m/min.

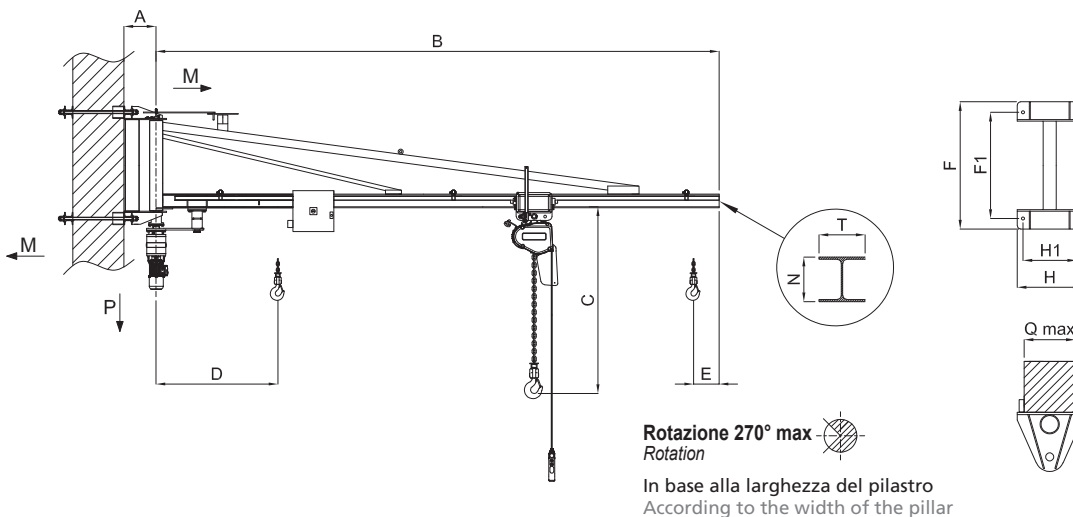

GRU A BANDIERA
JIB CRANES

Gru a bandiera a colonna

Column mounted jib cranes

TIPO CZ

con braccio in canalina
con plinto spostabile

CZ TYPE
with channel profile arm
with movable plinth

DATI TECNICI

TECHNICAL DATA

Portata Capacity	Braccio Arm length	Gru tipo Crane type	Paranco Kito tipo Kito hoist type	Dimensioni Dimensions									Piastra base per tasselli Base plate for chemical anchors	Peso gru senza paranco Crane weight with no hoist	Peso plinto Plinth weight	P	M
				H mm	H1 mm	H2 mm	A mm	B mm	C mm	D mm	E mm	Ø G mm					
125	3	CZ 12/3	KQ1S-SD	3965	3400	3500	290	3055	395	485	130	1350	039U06	235	1400	450	725
125	4	CZ 12/4	KQ1S-SD	3965	3400	3500	290	4055	395	535	130	1500	039U06	250	1750	465	985
125	5	CZ 12/5	KQ1S-SD	3965	3400	3500	350	5055	395	595	130	1650	050U08	334	2100	555	1295
125	6	CZ 12/6	KQ1S-SD	3965	3400	3500	350	6070	395	665	130	1800	050U08	359	2500	585	1630
250	3	CZ 25/3	KQ3S-SD	3965	3400	3500	290	3055	395	485	130	1600	039U06	235	1980	585	1170
250	4	CZ 25/4	KQ3S-SD	3965	3400	3500	290	4050	395	575	130	1800	050U08	324	2490	685	1620
250	5	CZ 25/5	KQ3S-SD	3975	3400	3500	405	5070	395	635	130	2000	066C10	439	3070	810	2135
250	6	CZ 25/6	KQ3S-SD	3975	3165	3500	405	6070	395	665	130	2200	066C10	469	3700	845	2640
500	2	CZ 50/2	KQ5S-SD	3965	3400	3500	290	2050	410	385	250	1600	039U06	225	1980	855	1345
500	3	CZ 50/3	KQ5S-SD	3965	3400	3500	350	3050	410	570	250	1900	050U08	309	2770	950	2060
500	4	CZ 50/4	KQ5S-SD	3965	3165	3500	405	4070	410	640	160	2200	066C10	454	3700	1110	2985

Carichi calcolati secondo UNI EN 13001 parti 1 e 2.
Loads calculated according to UNI EN 13001 parts 1 and 2.

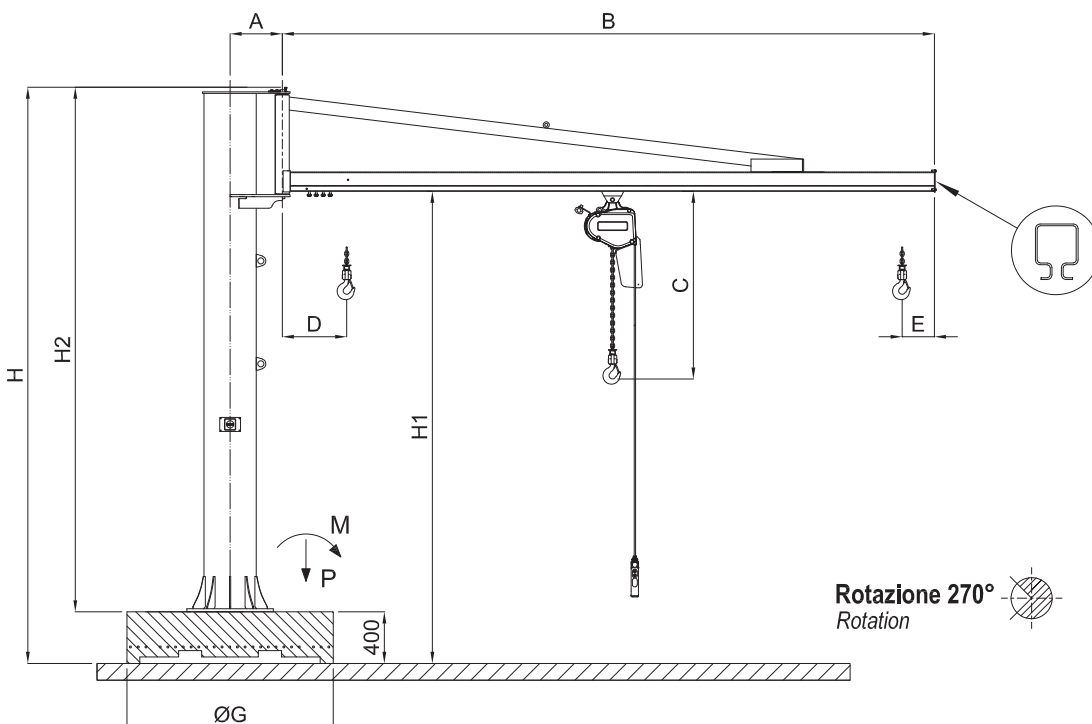

DATI TECNICI

TECHNICAL DATA

Portata Capacity	Braccio Arm length	Gru tipo Crane type	Paranco Kito tipo Hoist type	Dimensioni Dimensions											Piastra base per tasselli Base plate for chemical anchors	Peso gru senza paranco Crane weight with no hoist	Peso plinto Plinth weight	P	M
				H mm	H1 mm	H2 mm	A mm	B mm	C mm	D mm	E mm	N mm	T mm	Ø G mm					
125	3	CTZ 12/3	KQ1S-SD	3965	3730	3500	290	3010	415	695	180	160	82	1350	039U06	245	1400	475	780
125	4	CTZ 12/4	KQ1S-SD	3965	3690	3500	290	4010	415	695	180	200	100	1500	039U06	290	1750	525	1140
125	5	CTZ 12/5	KQ1S-SD	3965	3670	3500	350	5010	415	950	180	220	110	1650	050U08	399	2100	645	1570
125	6	CTZ 12/6	KQ1S-SD	3965	3650	3500	350	6010	415	950	180	240	120	1800	050U08	454	2500	705	2065
250	3	CTZ 25/3	KQ3S-SD	3965	3690	3500	290	3010	415	525	180	200	100	1600	039U06	265	1980	640	1255
250	4	CTZ 25/4	KQ3S-SD	3965	3670	3500	350	4010	415	695	180	220	110	1800	050U08	369	2490	750	1780
250	5	CTZ 25/5	KQ3S-SD	3975	3655	3500	405	5010	415	865	180	240	120	2000	066C10	519	3070	915	2445
250	6	CTZ 25/6	KQ3S-SD	3975	3595	3500	405	6010	415	1040	180	300	150	2200	066C10	624	3700	1035	3290
500	2	CTZ 50/2	KQ5S-SD	3965	3690	3500	290	2010	430	610	180	200	100	1600	039U06	240	1980	890	1415
500	3	CTZ 50/3	KQ5S-SD	3965	3670	3500	350	3010	430	865	180	220	110	1900	050U08	329	2770	985	2165
500	4	CTZ 50/4	KQ5S-SD	3965	3615	3500	405	4010	430	955	180	270	135	2200	066C10	509	3700	1185	3140

Carichi calcolati secondo UNI EN 13001 parti 1 e 2.

Loads calculated according to UNI EN 13001 parts 1 and 2.

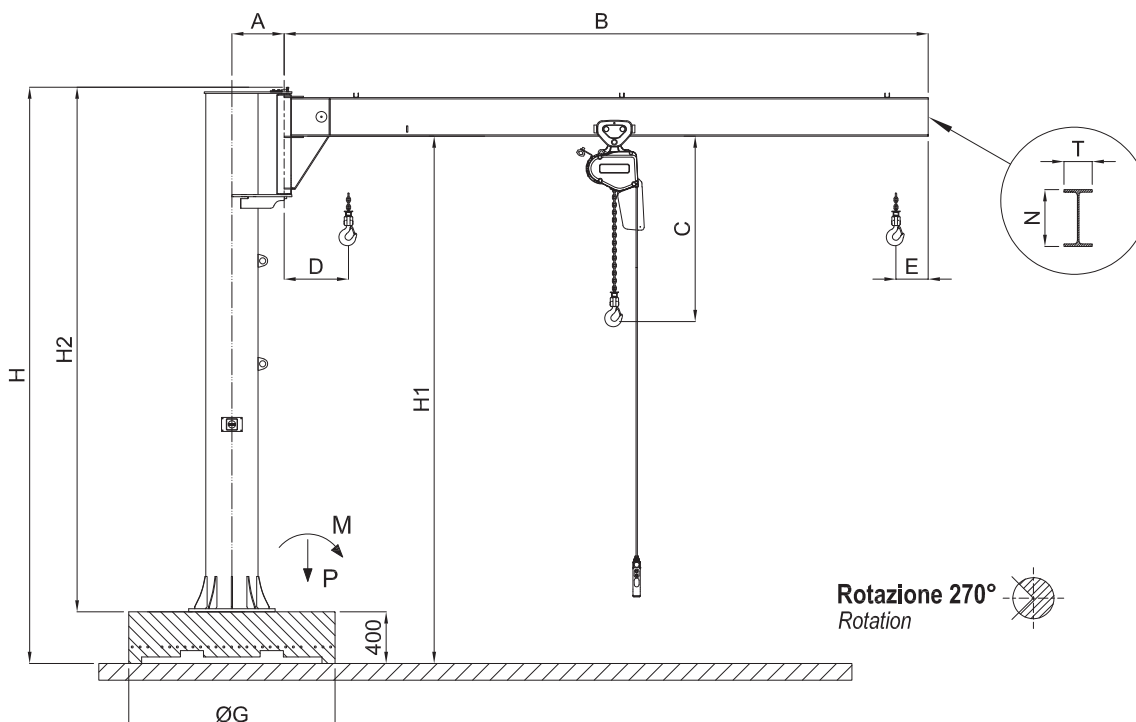

Gru a bandiera a colonna

Column mounted jib cranes

TIPO C2TZ

con braccio in trave con tiranti
con plinto spostabile

C2TZ TYPE
with overbraced arm
with movable plinth

DATI TECNICI

TECHNICAL DATA

Portata Capacity	Braccio Arm length	Gru tipo Crane type	Paranco Kito tipo Kito hoist type	Dimensioni Dimensions											Piastra base per tasselli Base plate for chemical anchors	Peso gru senza paranco Crane weight with no hoist	Peso plinto Plinth weight	P	M
				H mm	H1 mm	H2 mm	A mm	B mm	C mm	D mm	E mm	N mm	T mm	Ø G mm					
250	5	C2TZ 25/5	KQ3S-SD	3975	3175	3500	405	5010	415	1040	180	120	120	2000	066C10	482	3070	875	2325
250	6	C2TZ 25/6	KQ3S-SD	3975	3175	3500	405	6010	415	1040	180	120	120	2200	066C10	537	3700	935	2965
500	2	C2TZ 50/2	KQ5S-SD	3965	3410	3500	290	2010	430	610	180	120	120	1600	039U06	235	1980	885	1405
500	3	C2TZ 50/3	KQ5S-SD	3965	3410	3500	350	3010	430	865	180	120	120	1900	050U08	327	2770	985	2160
500	4	C2TZ 50/4	KQ5S-SD	3975	3175	3500	405	4010	430	955	180	120	120	2200	066C10	456	3700	1125	3000

Carichi calcolati secondo UNI EN 13001 parti 1 e 2.
Loads calculated according to UNI EN 13001 parts 1 and 2.

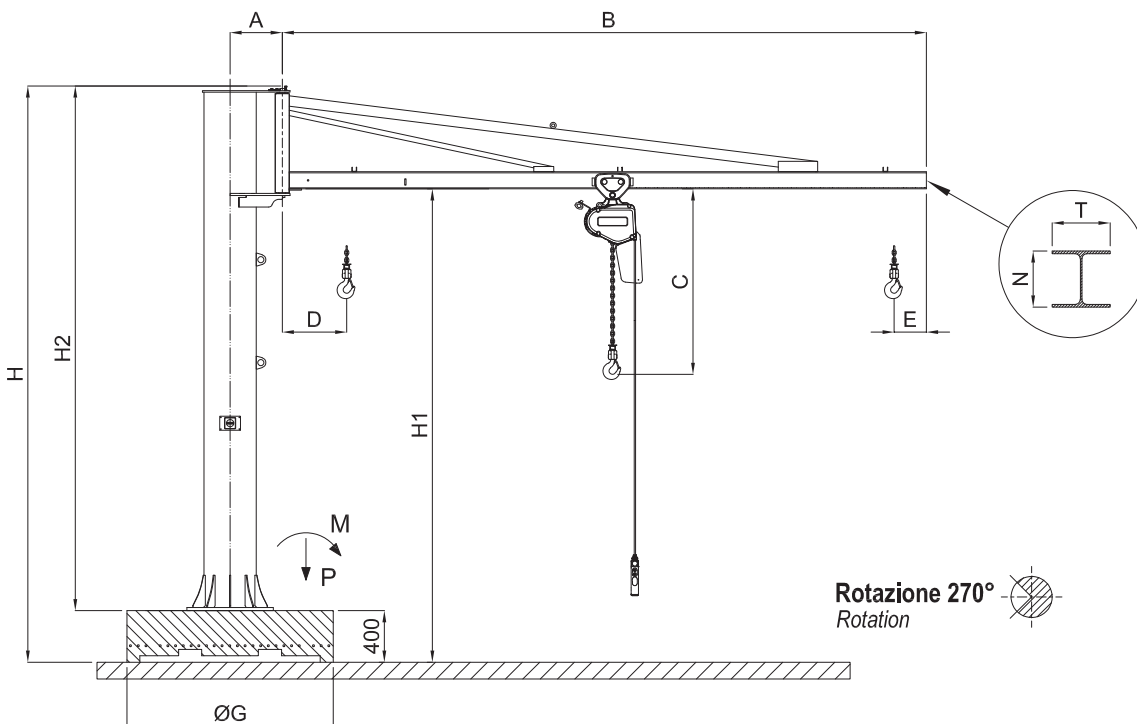

DATI TECNICI

TECHNICAL DATA

Portata Capacity	Sbraccio Arm length	Gru tipo Crane type	Paranco Kito tipo Kito hoist type	Dimensioni Dimensions							Piastra base per tasselli Base plate for chemical anchors	Piastra base per tirafondi Base plate for long bolts	Peso gru senza paranco Crane weight with no hoist	p*	M*
				H mm	H1 mm	A mm	B mm	C mm	D mm	E mm	Codice Code	Codice Code	kg		
125 + 125	2 + 2	C2B 12/ 2+2	KQ1S-SD	3565	3000	290	2055	395	385	130	039U06	039U06	255	570	790
125 + 125	3 + 3	C2B 12/ 3+3	KQ1S-SD	3565	3000	290	3055	395	485	130	039U06	039U06	285	570	790
125 + 125	4 + 4	C2B 12/ 4+4	KQ1S-SD	3565	3000	350	4055	395	535	130	050U08	050U08	415	685	1620
125 + 125	5 + 5	C2B 12/ 5+5	KQ1S-SD	3565	3000	350	5055	395	595	130	066C10	061F08	610	810	2135
125 + 125	6 + 6	C2B 12/ 6+6	KQ1S-SD	3565	3000	350	6070	395	665	130	066C10	061F08	660	845	2640
125 + 125	7 + 7	C2B 12/ 7+7	KQ1S-SD	3575	2765	405	7070	395	725	130	072C12	066F08	875	930	3390
125 + 125	8 + 8	C2B 12/ 8+8	KQ1S-SD	3575	2765	405	8080	395	840	130	072C12	066F08	1040	1215	4430
250 + 250	2 + 2	C2B 25/ 2+2	KQ3S-SD	3565	3000	290	2055	395	385	130	039U06	039U06	255	855	1345
250 + 250	3 + 3	C2B 25/ 3+3	KQ3S-SD	3565	3000	350	3055	395	485	130	050U08	050U08	285	950	2060
250 + 250	4 + 4	C2B 25/ 4+4	KQ3S-SD	3565	3000	350	4055	395	575	130	066C10	061F08	595	1110	2985
250 + 250	5 + 5	C2B 25/ 5+5	KQ3S-SD	3575	2765	405	5055	395	635	130	072C12	066F08	765	1150	3780
250 + 250	6 + 6	C2B 25/ 6+6	KQ3S-SD	3575	2765	405	6070	395	665	130	072C12	066F08	820	1355	4695
250 + 250	7 + 7	C2B 25/ 7+7	KQ3S-SD	3575	2765	405	7070	395	770	160	072C12	066F08	985	1395	5570
250 + 250	8 + 8	C2B 25/ 8+8	KQ3S-SD	3580	2655	470	8080	395	840	160	100C16	072F12	1485	1780	7080
500 + 500	2 + 2	C2B 50/ 2+2	KQ5S-SD	3565	3000	350	2050	410	385	250	066C10	061F08	530	1640	2725
500 + 500	3 + 3	C2B 50/ 3+3	KQ5S-SD	3565	3000	350	3050	410	570	250	066C10	061F08	560	1675	4030
500 + 500	4 + 4	C2B 50/ 4+4	KQ5S-SD	3575	2765	405	4070	410	640	160	072C12	066F08	800	1880	5480
500 + 500	5 + 5	C2B 50/ 5+5	KQ5S-SD	3575	2765	405	5070	410	640	160	090C16	066F08	955	2010	6890
500 + 500	6 + 6	C2B 50/ 6+6	KQ5S-SD	3580	2655	470	6080	410	740	160	100C16	072F12	1215	2205	8525
500 + 500	7 + 7	C2B 50/ 7+7	KQ5S-SD	3580	2655	470	7080	410	770	160	100C12	072F12	1295	2270	10120
1000 + 1000	2 + 2	C2B 100/ 2+2	KQ10S-SD	3575	2765	405	2070	465	640	310	090C16	066F08	790	3215	8225
1000 + 1000	3 + 3	C2B 100/ 3+3	KQ10S-SD	3575	2765	405	3070	465	640	310	090C16	066F08	845	3215	8225
1000 + 1000	4 + 4	C2B 100/ 4+4	KQ10S-SD	3580	2655	470	4080	465	740	310	100C12	072F12	1105	3485	11270
1000 + 1000	5 + 5	C2B 100/ 5+5	KQ10S-SD	3580	2655	470	5080	465	790	310	100C12	072F12	1180	3630	14265

Carichi calcolati secondo UNI EN 13001 parti 1 e 2.
Loads calculated according to UNI EN 13001 parts 1 and 2.

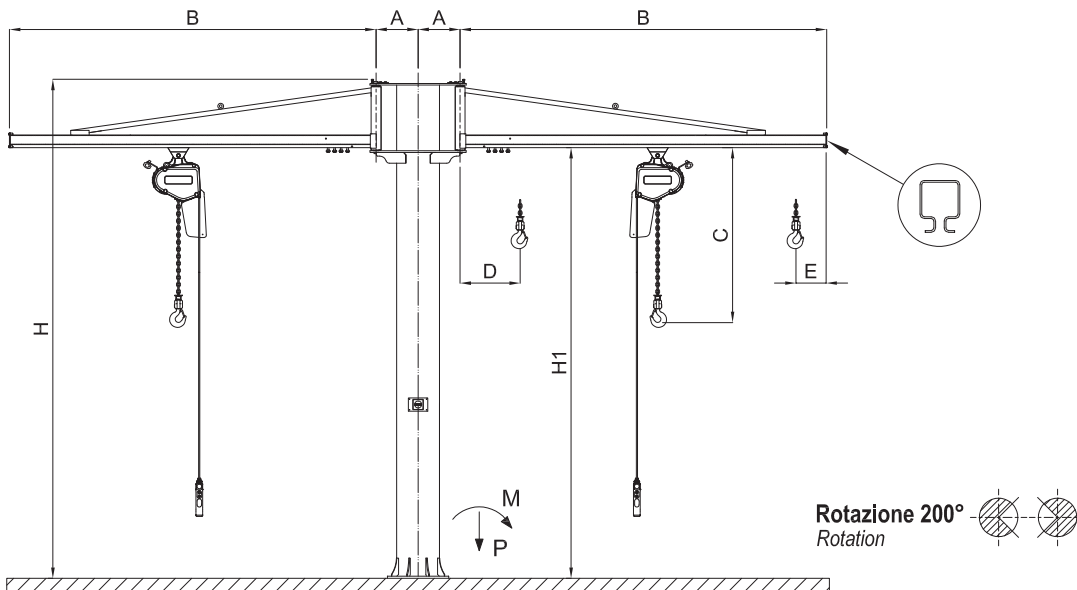

GRU A BANDIERA
JIB CRANES

DATI TECNICI

TECHNICAL DATA

Portata Capacity	Sbraccio Arm length	Gru tipo Crane type	Paranco Kito tipo Kito hoist type	Dimensioni Dimensions										Piastra base per tasselli Base plate for chemical anchors	Piastra base per tirafondi Base plate for long bolts	Peso gru senza paranco Crane weight with no hoist	P	M
				H mm	H1 mm	A mm	B mm	C mm	D mm	E mm	N mm	T mm	Codice Code	Codice Code	kg	daN	daN	
125 + 125	2 + 2	CT2B 12/ 2+2	KQ1S-SD	3565	3350	290	2010	415	610	180	140	73	039U06	039U06	260	595	805	
125 + 125	3 + 3	CT2B 12/ 3+3	KQ1S-SD	3565	3330	290	3010	415	695	180	160	82	039U06	039U06	315	640	1255	
125 + 125	4 + 4	CT2B 12/ 4+4	KQ1S-SD	3565	3290	350	4010	415	695	180	180	100	050U08	050U08	495	750	1780	
125 + 125	5 + 5	CT2B 12/ 5+5	KQ1S-SD	3565	3270	350	5010	415	950	180	200	110	066C10	061F08	675	915	2445	
125 + 125	6 + 6	CT2B 12/ 6+6	KQ1S-SD	3565	3250	350	6010	415	950	180	220	120	066C10	061F08	790	1035	3290	
125 + 125	7 + 7	CT2B 12/ 7+7	KQ1S-SD	3575	3195	405	7010	415	1125	180	300	150	072C12	066F08	1235	1135	4210	
125 + 125	8 + 8	CT2B 12/ 8+8	KQ1S-SD	3575	3165	405	8010	415	1210	180	330	160	072C12	066F08	1445	1445	5465	
250 + 250	2 + 2	CT2B 25/ 2+2	KQ3S-SD	3565	3330	290	2010	415	525	180	160	82	039U06	039U06	270	890	1415	
250 + 250	3 + 3	CT2B 25/ 3+3	KQ3S-SD	3565	3290	350	3010	415	695	180	200	100	050U08	050U08	450	985	2165	
250 + 250	4 + 4	CT2B 25/ 4+4	KQ3S-SD	3565	3270	350	4010	415	865	180	220	110	066C10	061F08	620	1185	3140	
250 + 250	5 + 5	CT2B 25/ 5+5	KQ3S-SD	3575	3255	405	5010	415	1040	180	240	120	072C12	066F08	940	1260	4090	
250 + 250	6 + 6	CT2B 25/ 6+6	KQ3S-SD	3575	3195	405	6010	415	1040	180	300	150	072C12	066F08	1160	1535	5295	
250 + 250	7 + 7	CT2B 25/ 7+7	KQ3S-SD	3575	3165	405	7010	415	1125	180	330	160	072C12	066F08	1360	1655	6595	
250 + 250	8 + 8	CT2B 25/ 8+8	KQ3S-SD	3580	3135	470	8010	415	1300	180	360	170	100C16	072F12	1900	2055	8340	
500 + 500	2 + 2	CT2B 50/ 2+2	KQ5S-SD	3565	3290	350	2010	430	610	180	200	100	066C10	061F08	490	1665	2840	
500 + 500	3 + 3	CT2B 50/ 3+3	KQ5S-SD	3565	3270	350	3010	430	865	180	220	110	066C10	061F08	540	1750	4260	
500 + 500	4 + 4	CT2B 50/ 4+4	KQ5S-SD	3575	3225	405	4010	430	955	180	270	135	072C12	066F08	920	2015	5900	
500 + 500	5 + 5	CT2B 50/ 5+5	KQ5S-SD	3575	3195	405	5010	430	1040	180	300	150	090C16	066F08	1150	2205	7565	
500 + 500	6 + 6	CT2B 50/ 6+6	KQ5S-SD	3580	3165	470	6010	430	1130	180	330	160	100C16	072F12	1550	2495	9625	
500 + 500	7 + 7	CT2B 50/ 7+7	KQ5S-SD	3580	3135	470	7010	430	1215	180	360	170	100C12	072F12	1780	2655	11760	
1000 + 1000	2 + 2	CT2B 100/ 2+2	KQ10S-SD	3575	3275	405	2010	490	880	190	220	110	090C16	066F08	725	2015	5900	
1000 + 1000	3 + 3	CT2B 100/ 3+3	KQ10S-SD	3575	3195	405	3010	490	965	190	300	150	090C16	066F08	965	3215	8225	
1000 + 1000	4 + 4	CT2B 100/ 4+4	KQ10S-SD	3580	3165	470	4010	490	1055	190	330	160	100C12	072F12	1335	3485	11270	
1000 + 1000	5 + 5	CT2B 100/ 5+5	KQ10S-SD	3580	3135	470	5010	490	1140	190	360	170	100C12	072F12	1535	3630	14265	

Carichi calcolati secondo UNI EN 13001 parti 1 e 2.
Loads calculated according to UNI EN 13001 parts 1 and 2.

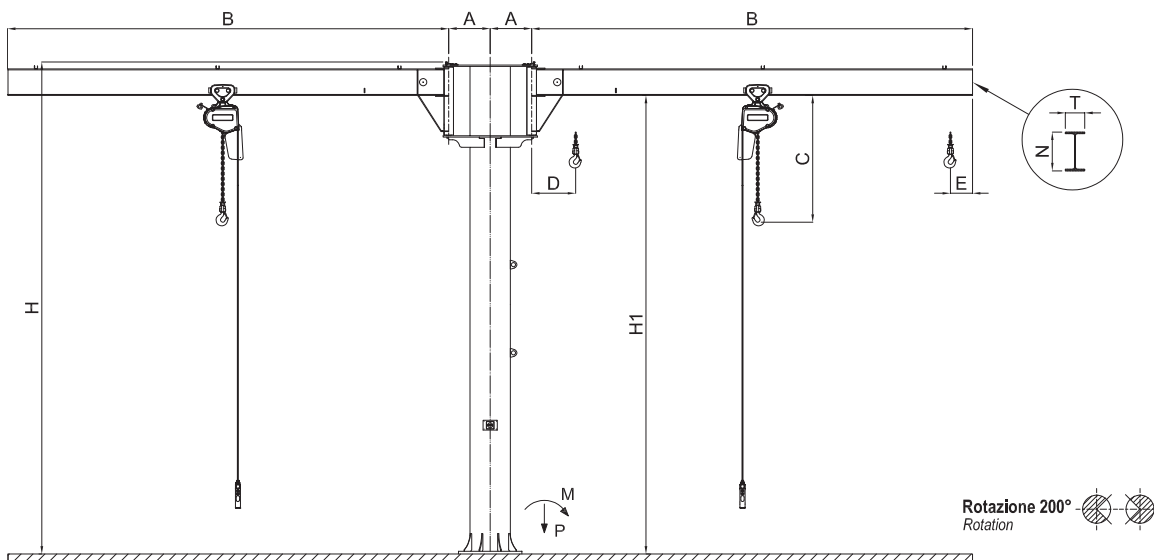

DATI TECNICI

TECHNICAL DATA

Portata Capacity daN	Sbraccio Arm length m	Gru tipo Crane type	Paranco Kito tipo Kito hoist type	Dimensioni Dimensions										Piastra base per tasselli Base plate for chemical anchors	Piastra base per tirafondi Base plate for long bolts	Peso gru senza paranco Crane weight with no hoist	P daN	M daN
				H mm	H1 mm	A mm	B mm	C mm	D mm	E mm	N mm	T mm	Codice Code	Codice Code	kg			
250 + 250	4 + 4	C2T 2B 25/ 4+4	KQ3S-SD	3565	3010	350	4010	415	865	180	120	120	066C10	061F08	725	1125	3000	
250 + 250	5 + 5	C2T 2B 25/ 5+5	KQ3S-SD	3575	2775	405	5010	415	1040	180	120	120	072C12	066F08	860	1185	3875	
250 + 250	6 + 6	C2T 2B 25/ 6+6	KQ3S-SD	3575	2775	405	6010	415	1040	180	140	140	072C12	066F08	970	1400	4815	
250 + 250	7 + 7	C2T 2B 25/ 7+7	KQ3S-SD	3575	2775	405	7010	415	1125	180	140	140	072C12	066F08	1035	1435	5710	
250 + 250	8 + 8	C2T 2B 25/ 8+8	KQ3S-SD	3580	2665	470	8010	415	1300	180	160	160	100C16	072F12	1515	1780	7080	
500 + 500	2 + 2	C2T 2B 50/ 2+2	KQ5S-SD	3565	3010	350	2010	430	610	180	120	120	066C10	061F08	550	1665	2840	
500 + 500	3 + 3	C2T 2B 50/ 3+3	KQ5S-SD	3565	3010	350	3010	430	865	180	120	120	066C10	061F08	605	1705	4180	
500 + 500	4 + 4	C2T 2B 50/ 4+4	KQ5S-SD	3575	2775	405	4010	430	955	180	120	120	072C12	066F08	805	1940	5720	
500 + 500	5 + 5	C2T 2B 50/ 5+5	KQ5S-SD	3575	2775	405	5010	430	1040	180	140	140	090C16	066F08	1000	2090	7220	
500 + 500	6 + 6	C2T 2B 50/ 6+6	KQ5S-SD	3580	2665	470	6010	430	1130	180	140	140	100C16	072F12	1185	2280	8865	
500 + 500	7 + 7	C2T 2B 50/ 7+7	KQ5S-SD	3580	2665	470	7010	430	1215	180	140	140	100C12	072F12	1335	2395	10715	
500 + 500	8 + 8	C2T 2B 50/ 8+8	KQ5S-SD	3580	2560	565	8010	430	1390	180	160	160	100C12	072F12	1555	2450	12385	
1000 + 1000	3 + 3	C2T 2B 100/ 3+3	KQ10S-SD	3580	2780	405	3010	490	970	190	140	140	090C16	066F08	870	3170	8140	
1000 + 1000	4 + 4	C2T 2B 100/ 4+4	KQ10S-SD	3580	2665	470	4010	490	1140	190	160	160	090C16	072F12	975	3375	10995	
1000 + 1000	5 + 5	C2T 2B 100/ 5+5	KQ10S-SD	3580	2665	470	5010	490	1190	190	160	160	100C12	072F12	1280	3440	13680	
1000 + 1000	6 + 6	C2T 2B 100/ 6+6	KQ10S-SD	3580	2310	565	6010	490	1190	190	180	180	100C12	072F12		3515	16625	
1000 + 1000	7 + 7	C2T 2B 100/ 7+7	KQ10S-SD	3580	2310	565	7010	490	1190	190	180	180	100C12	072F12		3635	19700	

Carichi calcolati secondo UNI EN 13001 parti 1 e 2.
Loads calculated according to UNI EN 13001 parts 1 and 2.

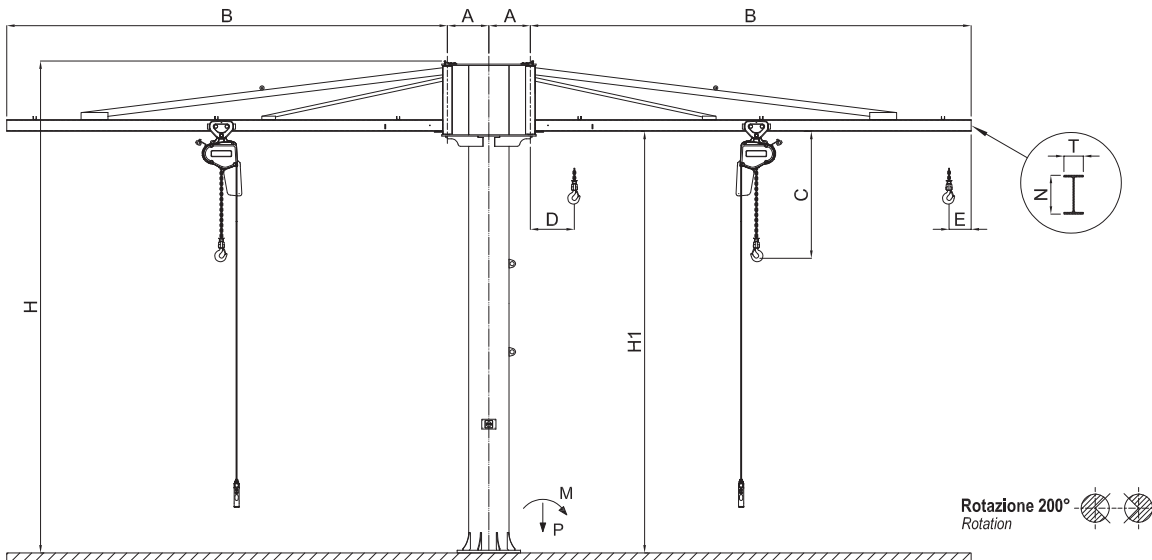

GRU A BANDIERA
JIB CRANES

DATI TECNICI

TECHNICAL DATA

Piastra di base Base plate	Fori Holes	Diametro fori Holes diameter	Tirafondi Long bolts	A	ØD	ØI	l	α	Coppia di serraggio Tightening torque
Codice Code	n.	ØF mm	Tipo type	mm	mm	mm	mm	gradi	Nxm
039U06	6	20	M18	400	390	330	-	60°	155
050U08	8	20	M18	510	500	440	-	45°	155
061F08	8	30	M27	620	610	530	-	45°	465
066F08	8	30	M27	670	660	580	-	45°	465
080F14	14	30	M27	810	800	720	-	25,71°	465
090F16	16	30	M27	900	-	-	820	-	465
100F16	16	30	M27	1000	-	-	920	-	465
100F1633	16	36	M33	1000	-	-	920	-	850
11F020	20	36	M33	1100	-	-	1020	-	850
12F020	20	36	M33	1200	-	-	1120	-	850

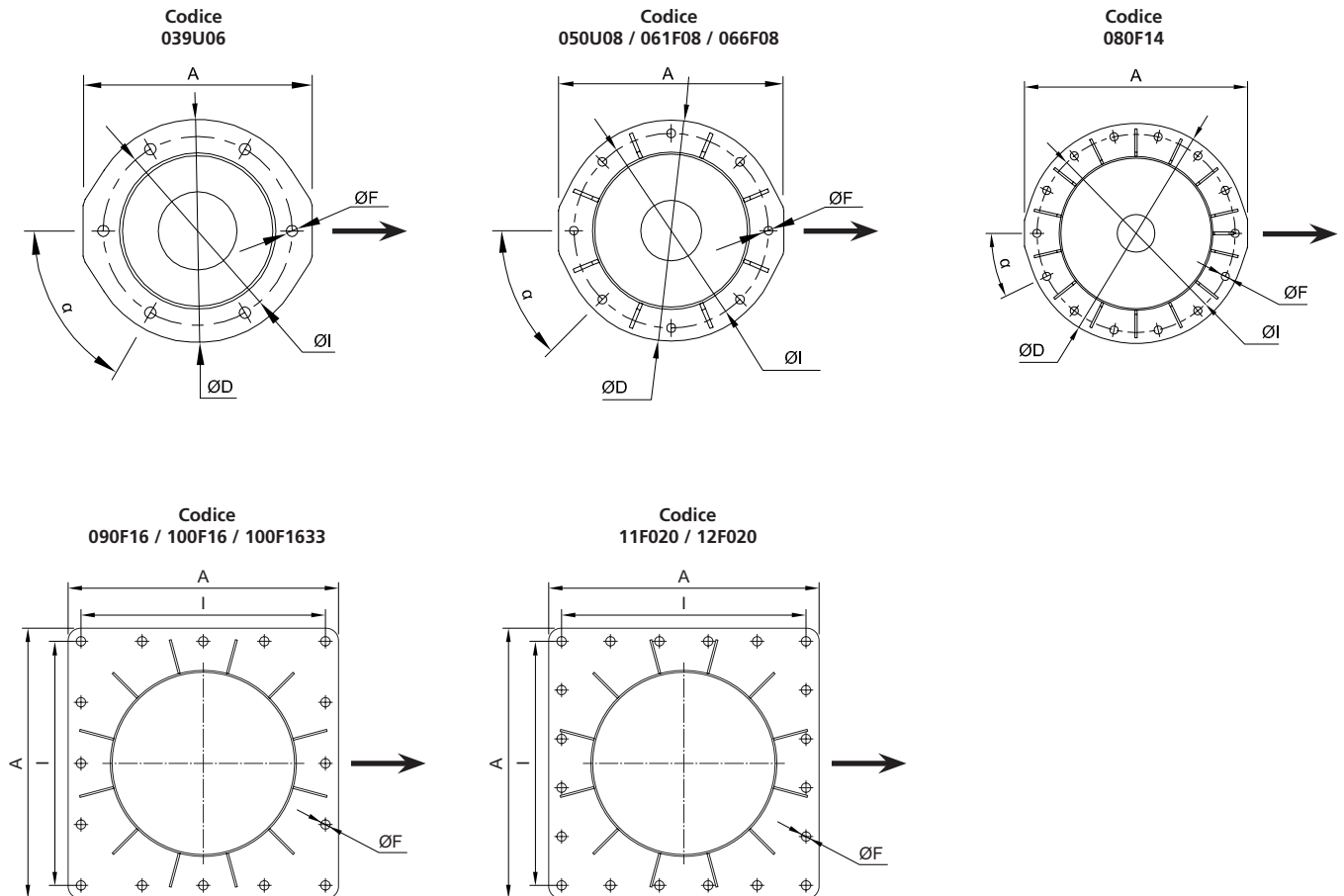

→
La freccia indica la posizione zero del braccio.
The arrow indicates the position zero of the arm.

DATI TECNICI

TECHNICAL DATA

Portata gru Capacity	Kg	125								250								500							
Sbraccio Arm length	m	2	3	4	5	6	7	8	2	3	4	5	6	7	8	2	3	4	5	6	7	8			
B	mm	900	1100	1200	1250	1300	1400	1500	1100	1200	1300	1400	1500	1700	1800	1300	1400	1600	1700	1800	1900	2000			
H	mm	800	800	900	900	900	1000	1000	800	900	1000	1000	1000	1000	1000	1000	1000	1000	1000	1000	1000	1000			
P	mm	500	500	500	500	500	750	50	500	500	500	750	750	750	750	500	500	750	750	750	750	750			
P1	mm	70	70	70	70	70	100	100	70	70	70	100	100	100	100	70	70	100	100	100	100	100			
Codice piastra Plate code		039U06	039U06	039U06	050U08	050U08	061F08	061F08	039U06	039U06	050U08	061F08	061F08	061F08	066F08	039U06	050U08	061F08	061F08	066F08	066F08	080F14			

Portata gru Capacity	Kg	1000								2000							
Sbraccio Arm length	m	2	3	4	5	6	7	8	3	4	5	6	7	8			
B	mm	1600	1800	1900	2000	2100	2300	2400	2100	2300	2500	2600	2800	3000			
H	mm	1000	1000	1200	1200	1200	1200	1200	1200	1200	1200	1300	1300	1200			
P	mm	750								750							
P1	mm	100								100							
Codice piastra Plate code		061F08	061F08	066F08	066F08	080F14	080F14	080F14	066F08	080F14	080F14	080F14	080F14	080F14			

- * Misure valutate per calcestruzzo con resistenza $R > 300 \text{ daN/cm}^2$, pressione massima sul terreno $p \sim 1.5 \text{ Dn/cm}^2$.
- ** Il dimensionamento del plinto di fissaggio delle gru a bandiera deve essere fatto da un tecnico specializzato ed abilitato in funzione di quelli che sono i carichi specifici delle gru da installare, che vengono indicati sulle tabelle tecniche FAS e delle reali caratteristiche del suolo dove verrà realizzato. Le misure riportate da FAS nelle tabelle devono essere esclusivamente intese come indicative ed utilizzate per poter permettere di valutare la posizione della gru nel luogo di installazione e definire quindi anche le caratteristiche dimensionali al momento dell'acquisto.
- * Dimensions calculated with concrete resistance $R > 300 \text{ daN/cm}^2$, max pressure on the ground $1,5 \text{ Dn/cm}^2$
- ** The dimensioning of the jib crane fixing plinth must be done by a specialized technician and enabled according to the specific loads of the cranes to be installed, which are indicated on the FAS technical tables and the real characteristics of the ground where it will be built. The measurements reported by FAS in the tables must be exclusively intended as indicative and used to enable the crane's position to be assessed at the place of installation and therefore also to define the dimensional characteristics at the time of purchase.

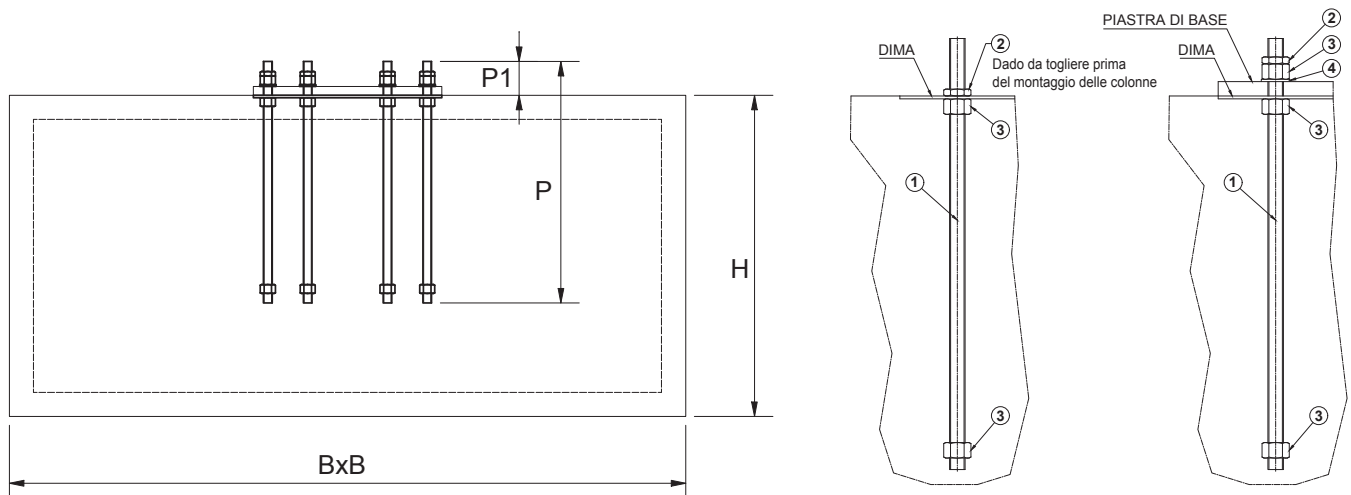

- 1 Piastra base della gru
 - 2 Maschera di lamiera
 - 3 Dado alto
 - 4 Dado basso
 - 5 rondella
 - 6 Tirafondo
- 1 Base plate of the crane
 - 2 Sheet mask
 - 3 High nut
 - 4 Thin nut
 - 5 Spacer
 - 6 Anchoring bolt

Gru a bandiera a colonna

Column mounted jib cranes

PIASTRE DI BASE PER FISSAGGIO MEDIANTE TASSELLI CHIMICI

BASE PLATES FOR MOUNTING
WITH CHEMICAL ANCHORS

CARATTERISTICHE

SPECIFICATION

The table shows the drawings of the base plates to be fixed to the floor with chemical anchor bolts. For the stability of the jib crane, each bolt will be subject to a tensile strength of ~ 31.25 kN. For the reliability of the anchoring system it is still essential that the floor where the crane is anchored meets the features listed below (in addition to the loads arising from the operation of the crane itself, which can be calculated from the table above):

- **Concrete strength not less than $R_{cK} \geq 30 \text{ N/mm}^2$;**
- **Floor minimum thickness 180 mm (M16) and 220 mm (M20);**
- **Floor with relevant metal reinforcement to withstand the aforementioned strength around the bolts.**

The suitability for floor mounting can be ensured by the designer of the building or otherwise a proper survey of the floor area where the crane will be installed should be performed by a designated person.

La tabella rappresenta i disegni delle piastre di base il cui fissaggio a pavimento è previsto con bulloni ad ancoraggio chimico.

Per la stabilità della bandiera, ciascun bullone sarà soggetto ad una trazione di ~31.25 kN.

Per la sicura affidabilità del sistema di ancoraggio è indispensabile che il pavimento su cui si ancora la gru soddisfi alle sotto indicate caratteristiche (oltre ovviamente ai carichi derivanti dall'esercizio della gru stessa, e deducibili dalla tabella soprastante):

- **Resistenza del calcestruzzo non inferiore a $R_{cK} \geq 30 \text{ N/mm}^2$**
- **Spessore minimo pavimento 180 mm (M16) e 220 mm (M20);**
- **Pavimento provvisto di adeguata armatura metallica per resistere, nell'intorno dei bulloni, alla trazione indicata.**

L'idoneità del pavimento, per tale ancoraggio, potrà essere assicurata dal progettista del capannone o diversamente dovrà essere eseguito a cura di un incaricato, un adeguato sondaggio nella zona di pavimento dove la gru verrà installata.

DATI TECNICI TECHNICAL DATA

Piastra di base Base plate	Fori Holes	Diametro fori Holes diameter	Tasselli chimici Chemical anchors	Profondità foratura tassello Anchor depth	Spessore minimo pavimento Floor min. thickness	A	ØD	ØI	I	α
Codice Code	n.	ØF mm	Tipo type	mm	mm	mm	mm	mm	mm	gradi
039U06	6	20	M16	125	180	400	390	330	-	60°
050U08	8	20	M16	125	180	510	500	440	-	45°
066C10	10	19	M16	125	180	670	660	600	-	36°
072C12	12	19	M16	125	180	720	-	-	640	-
090C16	16	19	M16	125	180	900	-	-	820	-
100C16	16	19	M16	125	180	1000	-	-	930	-
100C12	12	25	M20	170	220	1000	-	-	930	-

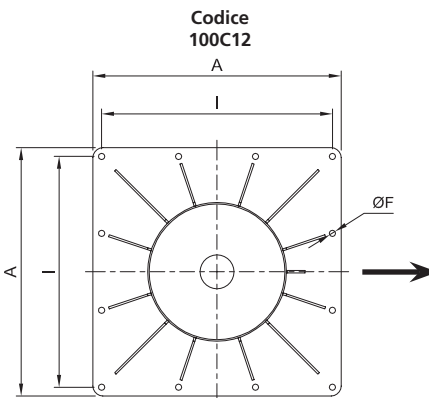
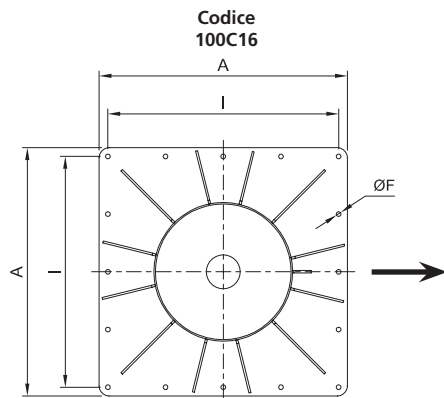
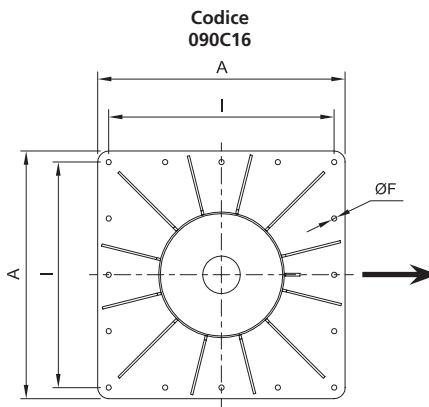
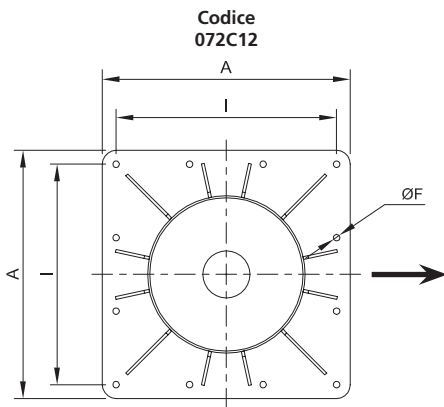
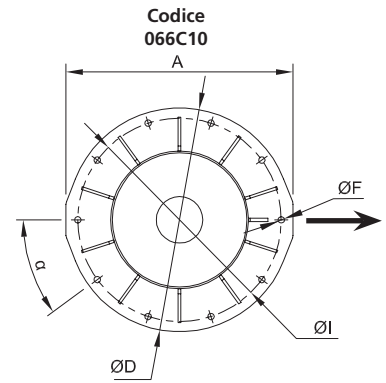
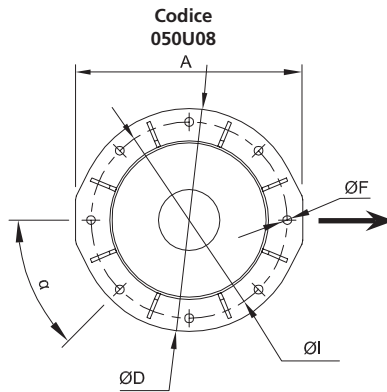
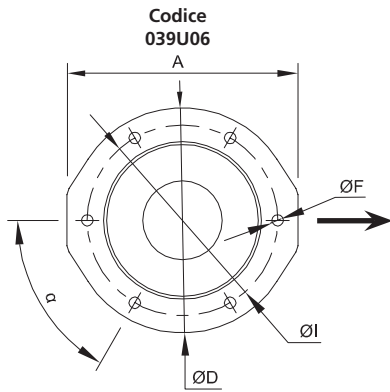

→ La freccia indica la posizione zero del braccio.
The arrow indicates the position zero of the arm.

CARATTERISTICHE SPECIFICATION

The wall-mounted cranes are anchored to the pillar by means of tie rods and counter supports.
Upon request, FAS produces brackets for anchoring on the edge of the pillar or custom counter supports.
When ordering, always specify x and y dimensions.

Le gru a mensola vengono vincolate al pilastro mediante tiranti e controstaffe.
Su richiesta, FAS realizza mensole per imbragature sullo spigolo del pilastro o controstaffe particolari.
In fase di ordine, indicare sempre le misure x e y.

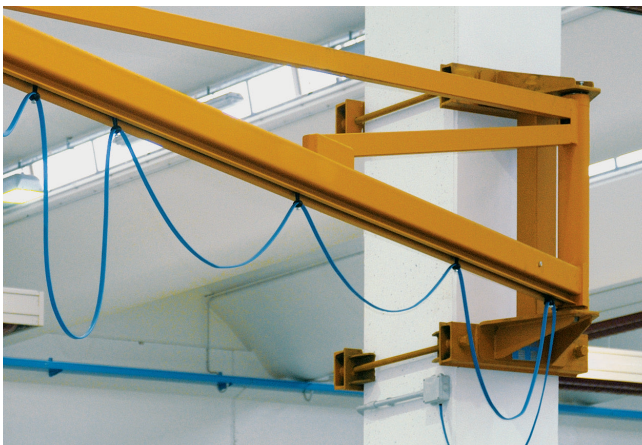
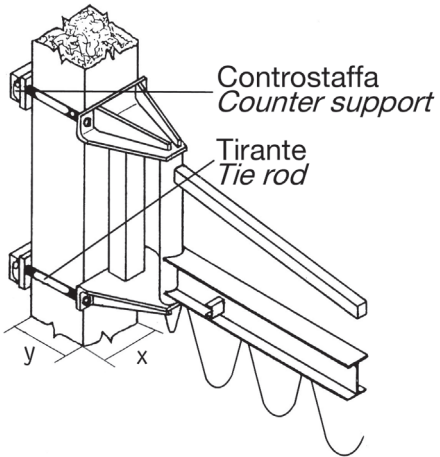

Imbragatura standard.
Standard anchoring.



Imbragatura su spigolo.
Edge anchoring.

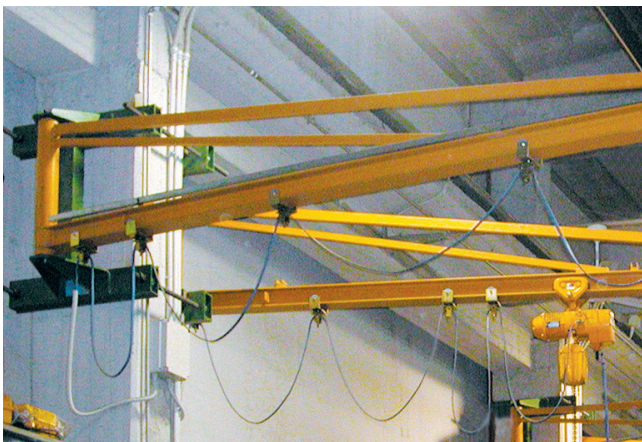

2 gru imbragate contrapposte.
2 cranes harnessed together.



Imbragatura mediante tasselli chimici.
Chemical bolts anchoring.



GRU A BANDIERA
JIB CRANES

CARATTERISTICHE
SPECIFICATION

Solutions designed according to specific customer requirements:

- Crane with double arm;
- Cranes to be palletized;
- Gantry cranes;
- Straight or curved monorails;
- Lifting equipment.

Soluzioni progettate e costruite in funzione delle specifiche richieste del cliente:

- Gru con doppio braccio;
- Gru pallettizzabili;
- Gru a portale;
- Monorotaie dritte o curve;
- Strutture di sollevamento in genere.



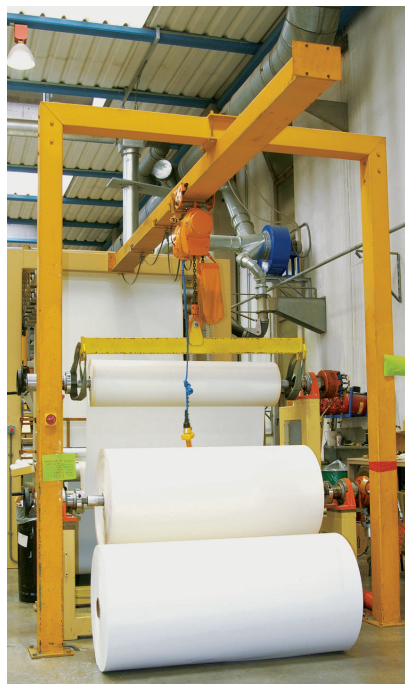

GRU A BANDIERA
JIB CRANES